

USER'S MANUAL  
**MS 5000**  
MAST CLIMBING WORK PLATFORM

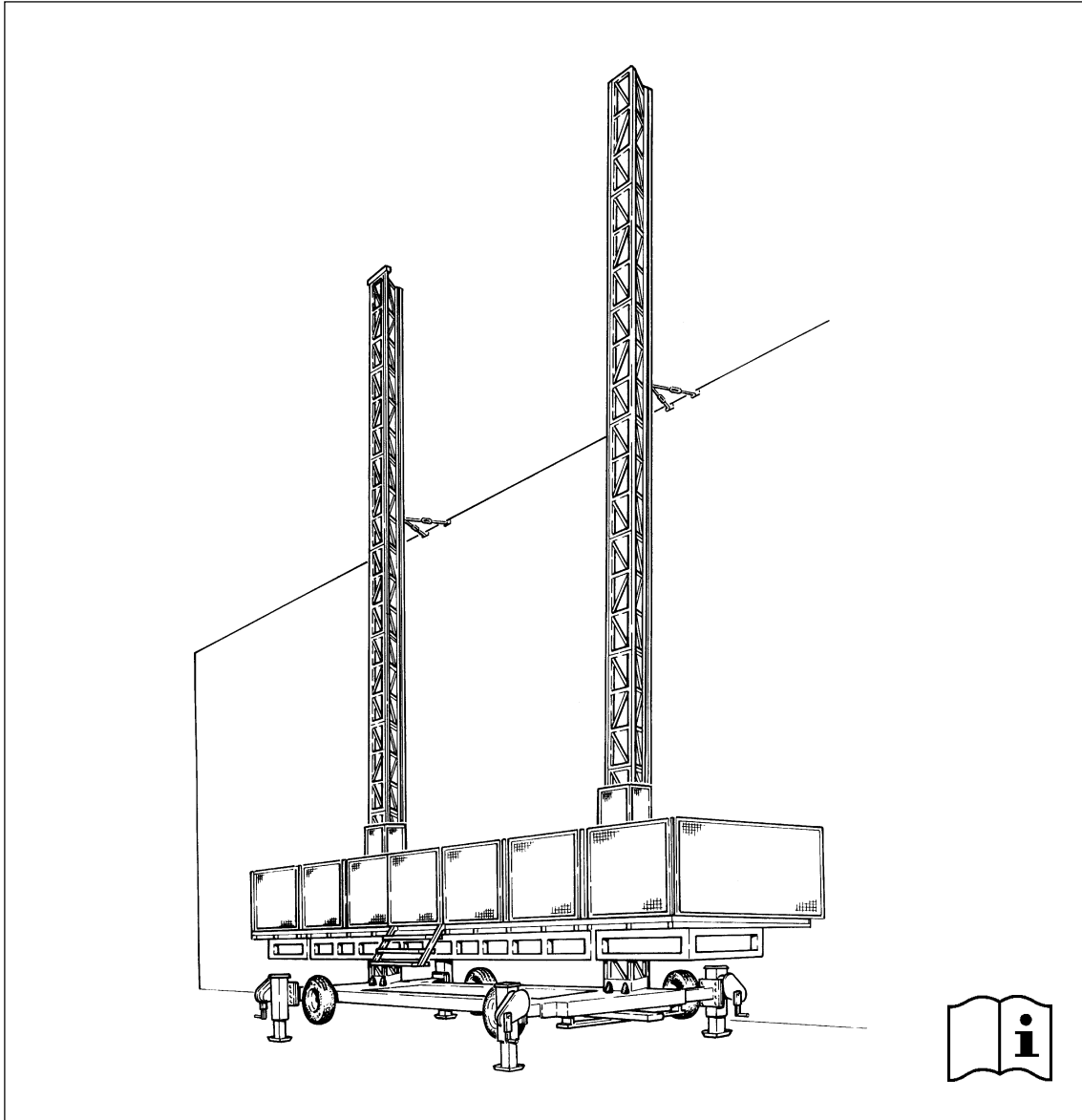

This manual is assigned to:

© 2000, HEK Manufacturing BV., Middelbeers, The Netherlands

Nothing contained in this publication may be copied, and/or published by means of printing, photocopying, microfilm or any other method without prior written permission from HEK Manufacturing B.V.

Drawings are illustrative only and do not necessarily show the design of the product on the market at any given point of time.



---

**HEK Manufacturing B.V.**

Westelbeersedijk 18  
5091 SM Middelbeers  
The Netherlands

Tel : +31 13 51 48 653  
Fax : +31 13 51 48 630

P.O. box 2  
5090 AA Middelbeers  
The Netherlands



## FOREWORD

For glazing, masonry or renovation work at height, the MS 5000 can be matched to any type of building. Heavy building components and their installation crews can be elevated and positioned exactly with optimum safety and efficiency.

This manual describes the installation, operation and maintenance of the mast climbing work platform.

The mast climbing work platform is provided with a rack and pinion drive.

The mast climbing work platform can be quickly moved and is easy to transport.

The mast climbing work platform can be freestanding or anchored.

The mast, which consists of separate elements, can easily be adjusted in height to match the height of the building work. The mast is easy to assemble from the platform.

The platform can be adjusted with regard to length and width to the shape of the façade.

The MS 5000 mast climbing work platform has a hold to run control system which makes it possible to stop at any desired height.

Every care has been taken in the construction of the mast climbing work platform to ensure that all safety aspects have been considered.

Depending on the application area, a choice can be made from different platform lengths, platform widths and permissible loading.

This instruction manual describes only the basic machine, in the standard configuration supplied by HEK Manufacturing BV.

**Read this instruction manual carefully before using the mast climbing work platform. Follow the safety precautions!**

**This manual is valid in combination with, as 5 L resp. 5 R, marked components only (chassis, platform, mast elements and platform elements).**

**CONTENTS**

FOREWORD	V	6. ASSEMBLY AND ANCHORING	6-1
CONTENTS	VI	6.1 Preparation for assembly	6-2
SURVEY OF ILLUSTRATIONS	VII	6.2 Ground support	6-3
EC DECLARATION OF CONFORMITY FOR MACHINES	VIII	6.3 Positioning the mast climbing work platform general	6-4
MEANING OF THE SYMBOLS USED	IX	6.3.1 Positioning the mast climbing work platform	6-5
		6.4 Assembly of the mast	6-7
		6.5 Anchoring the mast	6-10
		6.6 Adjusting the platform width	6-12
		6.7 Lightning protection	6-13
1. TECHNICAL DETAILS	1-1	7. OPERATION	7-1
1.1 General	1-1	7.1 General	7-1
1.2 Electrical installation	1-4	7.2 Preparation	7-1
1.3 Chassis	1-5	7.3 Testing	7-3
1.4 Platform construction and loading diagram	1-6	7.4 Brake test	7-3
1.4.1 Maximum loading	1-6	7.5 Operation from the platform	7-4
1.5 Anchor forces	1-7	7.6 Operation in an emergency situation	7-4
2. COMPONENT DESCRIPTION	2-1	8. DISASSEMBLY AND TRANSPORT	8-1
2.1 General description	2-1	9. MAINTENANCE	9-1
3. SAFETY	3-3	9.1 General	9-1
3.1 General	3-3	9.2 Maintenance intervals	9-1
3.2 Safety prior to use	3-3	9.3 The motor brake	9-4
3.3 Safety in use	3-3	9.3.1 Operation	9-4
3.4 Safety after use	3-4	9.3.2 Maintenance	9-5
3.5 Built-in and additional safety features	3-4	10. MALFUNCTION ANALYSIS	10-1
3.6 Personnel	3-5	11. MACHINE DISPOSAL	11-1
4. TRANSPORT	4-1	12. LIST OF KEYWORDS	12-1
4.1 Repositioning on the building site	4-2	A. CHECKLIST MAST CLIMBING WORK PLATFORMS TYPE B	APPENDICE-1
4.2 Repositioning with a crane	4-3	B. CHECKLIST MAST CLIMBING WORK PLATFORMS TYPE C	APPENDICE-5
5. CONTROL COMPONENTS	5-1		
5.1 Power supply socket for the platform	5-1		
5.2 Single phase outlet	5-1		
5.3 Platform control box	5-2		

---

**SURVEY OF ILLUSTRATIONS**

Fig.1	Dimensions	X
Fig.1-1	Platform components	1-2
Fig.1-2	Mast element	1-2
Fig.1-3	Fence posts	1-2
Fig.1-4	Chassis	1-5
Fig.1-5	Maximum load	1-6
Fig.1-6	Anchor forces	1-7
Fig.2-1	Basic set MS 5000	2-1
Fig.4-1	Transport MS 5000	4-1
Fig.4-2	Locking pin outrigger chassis	4-2
Fig.5-1	Platform power supply socket	5-1
Fig.5-2	Control box	5-2
Fig.6-1	Position machine	6-1
Fig.6-2	Ground support chassis	6-3
Fig.6-3	Distance to the facade	6-4
Fig.6-4	Locking pin outrigger chassis	6-5
Fig.6-5	Lower striker plate	6-5
Fig.6-6	Securing platform elements	6-5
Fig.6-7	Locking pin step	6-6
Fig.6-8	Securing platform posts and fences	6-6
Fig.6-9	Power supply socket	6-7
Fig.6-10	Main switch	6-7
Fig.6-11	Control buttons	6-8
Fig.6-12	Proximity switch	6-8
Fig.6-13	Mast element with mechanical end stop	6-9
Fig.6-14	Mast cover	6-9
Fig.6-15	Anchor	6-11
Fig.6-16	Outrigger platform extension	6-13
Fig.6-17	Anchor ramp	6-13
Fig.6-18	Lightning protection	6-13
Fig.7-1	Main switch	7-2
Fig.7-2	Emergency push-button	7-2
Fig.7-3	Brake lever platform	7-3
Fig.7-4	Push-buttons control box	7-4
Fig.7-5	Brake lever platform	7-4
Fig.8-1	Brake lever platform	8-1
Fig.8-2	Locking pin outrigger	8-2
Fig.8-3	Locking pin outrigger chassis	8-2
Fig.9-1	Motorbrake	9-4
Fig.9-2	Motorbrake	9-6

---

# EC DECLARATION OF CONFORMITY

**EC declaration of conformity for machines**  
(pursuant to Annex IIa of the Machine Directives 89/392/EEC)

We, **HEK Manufacturing bv**  
**Westelbeersedijk 18**  
**5091 SM Middelbeers**  
**The Netherlands**

hereby declare that, on the basis of its design and construction, the mast climbing work platform named below and brought into circulation by us conform to the relevant basic safety and health requirements contained in the EC Machine Directives.

Changes made to the machine without our consent invalidate this declaration.

This declaration applies to the mast climbing work platform:

**HEK MS 5000**

In accordance with: **EC Machine Directives 89/392/EG, Annex IV, including 91/368, 93/44**

EC number: **08/205/A 16-99/PM07490, 02-06-1999**

Certified by ('Notified Body'): **TÜV HANNOVER/SACHSEN ANHALT E.V. HANNOVER, GERMANY**

Date/Manufacturer's signature: **Middelbeers, the Netherlands, November 1st 1999**



Signatory: **P.M. Blom, deputy manager**



---

## MEANING OF THE SYMBOLS USED



**WARNING**  
Failing to (exactly) comply with the working or operating instructions may lead to serious injury, fatal accident, severe mechanical damage or operating losses.



During use, no person may stand **under** the machine.



Danger: High voltage.



Danger of falling objects.

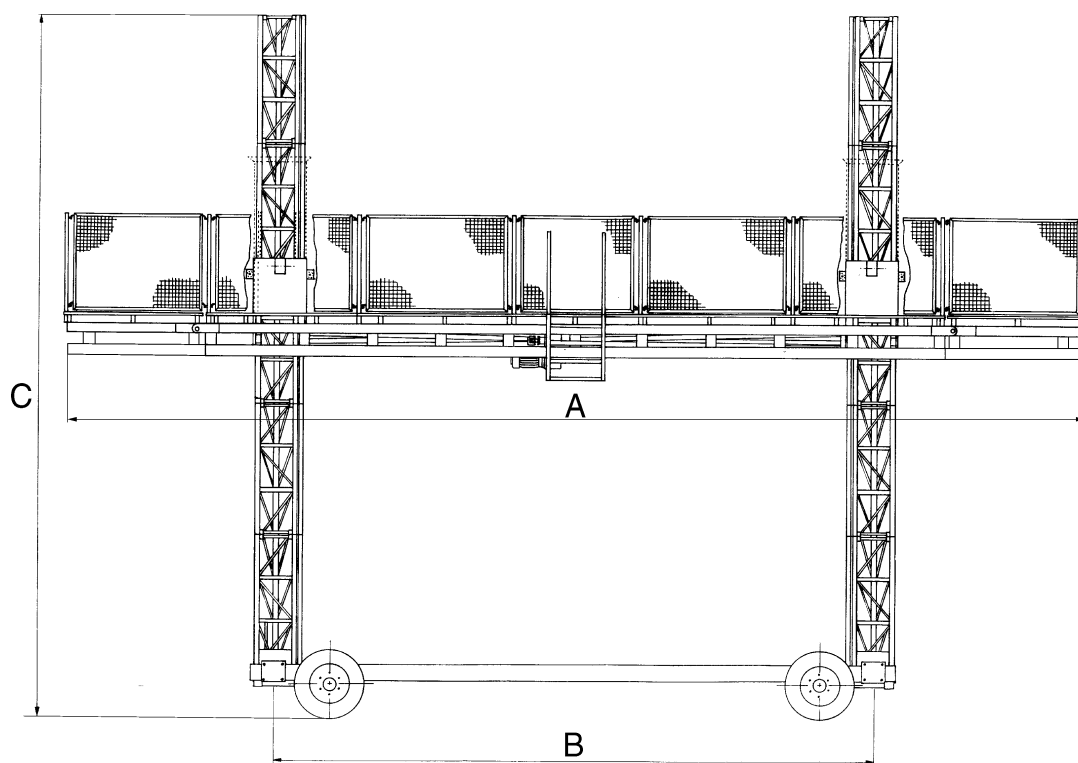

Fig.1 Dimensions

## 1. TECHNICAL DETAILS

The details in this manual are based on standard applications. In special situations, it may be possible to deviate from these. This may only be done with the prior written approval of the supplier.

This manual is valid in combination with, as 5 L resp. 5 R, marked components only (chassis, platform, mast elements and platform elements).

### 1.1 General

Description	MS 5000	
	Platform length (A)	8.5 - 15 m
Platform width	1.5 - 2.5 m	4.9 - 8.2 ft
Min. platform height	1.25 m	4.1 ft
Distance between mast centres (B)	6.9 m	22.3 ft
Max. anchor distance	6 - 8 m	19.7 - 26.2 ft
Height of first anchor	8 m	26.2 ft
Distance between cable guides	6 m	19.7 ft
Max. mastheight free-standing (C)	8 m	26.2 ft
Max. mastheight anchored (C)	100 m	328 ft
Max. mastheight above last anchor	0 m	0 ft
Mast type	DRK500	
Max. number of persons	4	
Platform speed 50 Hz machine	5.0 m/min	16.4 ft/min
Platform speed 60 Hz machine	5.2 m/min	17.1 ft/min
Loading capacity	see section 1.4	
Noise level	< 70 dB	
Maximum wind-force during erection	12,5 m/s (6 Beaufort)	41 ft/s (6 Beaufort)
Maximum wind-force during use freestanding	12,5 m/s (6 Beaufort)	41 ft/s (6 Beaufort)
Maximum wind-force during use anchored	15,7 m/s (7 Beaufort)	51.5 ft/s (7 Beaufort)

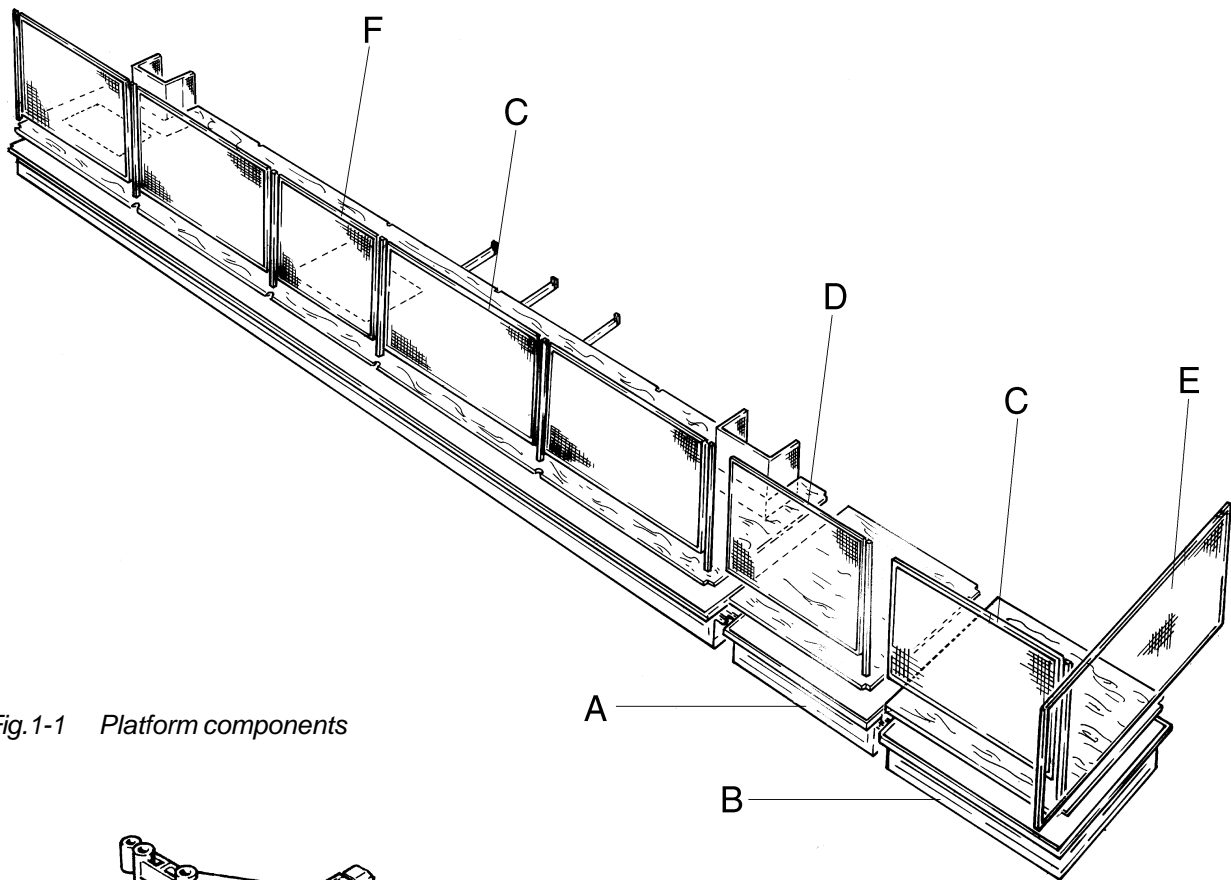

Fig.1-1 Platform components

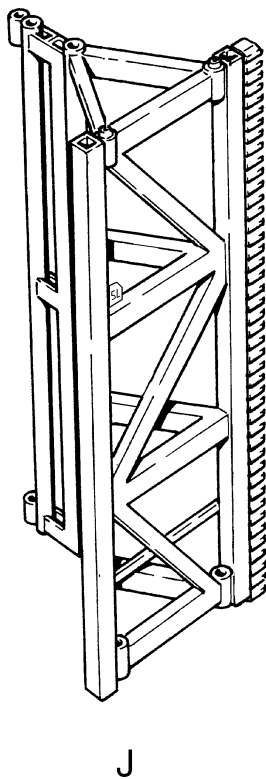

Fig.1-2 Mast element

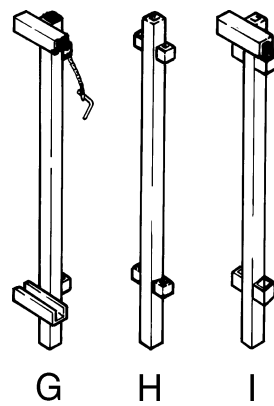

Fig.1-3 Fence posts

Part	l x b x h [mm]	weight [kg]	No. of bolts	bolt dim. & quality	torque [Nm]	other
Basic machine 8.5 m incl. chassis & fences	8500 x 2350 x 1920	4500	---	---	---	Max. platform extension façade side 1000 mm
Mast element 150	1508 x 570 x 565	86	4	M16 x 150 qual. 8.8	150	Module 8
Platform element 150	1500 x 1500 x 500	198	---	---	---	Max. platform extension façade side 1000 mm
Platform element 175	1750 x 1500 x 500	205	---	---	---	Max. platform extension façade side 1000 mm
Plug-in fence 150	1425 x 30 x 1080	16.2	---	---	---	---
Plug-in fence 175	1605 x 30 x 1080	18.2	---	---	---	---
End fence	3000 x 30 x 1080	32.0	---	---	---	---
Gate	1605 x 30 x 1080	17.1	---	---	---	---
Lengthwise post	1195 x 45 x 120	3.2	---	---	---	---
Gate side post	1210 x 110 x 120	3.4	---	---	---	---
End side post	1245 x 118 x 100	4.0	---	---	---	---

Part	l x b x h [in]	weight [lb]	No. of bolts	bolt dim. & quality	torque [lb ft]	other
Basic machine 27.9 ft incl. chassis & fences	334.6 x 92.5 x 75.6	9900	---	---	---	Max. platform extension façade side 39.4 inch
Mast element 150	59.4 x 22.4 x 22.2	189	4	M16 x 5.9 in qual. 8.8	111	Module 8
Platform element 150	59.1 x 59.1 x 19.7	436	---	---	---	Max. platform extension façade side 39.4 inch
Platform element 175	68.9 x 59.1 x 19.7	451	---	---	---	Max. platform extension façade side 39.4 inch
Plug-in fence 150	56.1 x 1.2 x 42.5	35.6	---	---	---	---
Plug-in fence 175	63.2 x 1.2 x 42.5	40.0	---	---	---	---
End fence	118.1 x 1.2 x 42.5	70.4	---	---	---	---
Gate	63.2 x 1.2 x 42.5	37.6	---	---	---	---
Lengthwise post	47.0 x 1.8 x 4.7	7.0	---	---	---	---
Gate side post	47.6 x 4.3 x 4.7	7.5	---	---	---	---
End side post	49.0 x 4.6 x 3.9	8.8	---	---	---	---

Meaning of the letters page 2-1:

A = Platform element 150

E = End fence

I = End side post

B = Platform element 175

F = Gate

J = Mast element 150

C = Plug-in fence 175

G = Lengthwise post

D = Plug-in fence 150

H = Gate side post

## 1.2 Electrical installation

Platform type		MS5000 220V - 60 Hz	MS5000 220V - 50 Hz	MS5000 400V - 50 Hz
Supply voltage		208 - 240 V	208 - 240 V	380 - 420 V
Number of motors		2	2	2
Rated power		2 x 4 kW	2 x 4 kW	2 x 4 kW
Maximum starting current		240 A	240 A	100 A
Nominal current		35 A	35 A	20 A
Nominal power consumption		16 kVA	16 kVA	16 kVA
Phases		3 + Pe	3 + Pe	3 + N + Pe
Fuse at building site (slow)		63 A	63 A	32 A
Control voltage		42 Vac	42 Vac	42 Vac
Power supply cable, under all conditions (building site to machine)	up to 40m / 131 ft	4 x 25 mm <sup>2</sup> / 4 x 0.039 in <sup>2</sup>	4 x 25 mm <sup>2</sup> / 4 x 0.039 in <sup>2</sup>	5 x 10 mm <sup>2</sup> / 5 x 0.016 in <sup>2</sup>
	up to 60m / 197 ft	4 x 35 mm <sup>2</sup> / 4 x 0.054 in <sup>2</sup>	4 x 35 mm <sup>2</sup> / 4 x 0.054 in <sup>2</sup>	5 x 16 mm <sup>2</sup> / 5 x 0.025 in <sup>2</sup>
	up to 90m / 295 ft	4 x 50 mm <sup>2</sup> / 4 x 0.078 in <sup>2</sup>	4 x 50 mm <sup>2</sup> / 4 x 0.078 in <sup>2</sup>	5 x 25 mm <sup>2</sup> / 5 x 0.039 in <sup>2</sup>
<i>Power supply cable, V &gt; 230 Vac (building site to machine)</i>	<i>up to 40m / 131 ft</i>	<i>4 x 16 mm<sup>2</sup> / 4 x 0.025 in<sup>2</sup></i>	<i>4 x 16 mm<sup>2</sup> / 4 x 0.025 in<sup>2</sup></i>	<i>-----</i>
	<i>up to 60m / 197 ft</i>	<i>4 x 25 mm<sup>2</sup> / 4 x 0.039 in<sup>2</sup></i>	<i>4 x 25 mm<sup>2</sup> / 4 x 0.039 in<sup>2</sup></i>	<i>-----</i>
	<i>up to 90m / 295 ft</i>	<i>4 x 35 mm<sup>2</sup> / 4 x 0.054 in<sup>2</sup></i>	<i>4 x 35 mm<sup>2</sup> / 4 x 0.054 in<sup>2</sup></i>	<i>-----</i>
Machine cable, under all conditions	up to 60m / 197 ft	4 x 10 mm <sup>2</sup> / 4 x 0.016 in <sup>2</sup> (0.90 kg/m / 0.60 lb/ft)	4 x 10 mm <sup>2</sup> / 4 x 0.016 in <sup>2</sup> (0.90 kg/m / 0.60 lb/ft)	5 x 6 mm <sup>2</sup> / 5 x 0.010 in <sup>2</sup> (0.64 kg/m / 0.43 lb/ft)
	up to 100m / 329ft	4 x 16 mm <sup>2</sup> / 4 x 0.025 in <sup>2</sup> (1.25 kg/m / 0.84 lb/ft)	4 x 16 mm <sup>2</sup> / 4 x 0.025 in <sup>2</sup> (1.25 kg/m / 0.84 lb/ft)	5 x 6 mm <sup>2</sup> / 5 x 0.010 in <sup>2</sup> (0.64 kg/m / 0.43 lb/ft)
	up to 150m / 492 ft	<i>-----</i>	<i>-----</i>	5 x 10 mm <sup>2</sup> / 5 x 0.016 in <sup>2</sup> (1.11 kg/m / 0.74 lb/ft)
<i>Machine cable, V &gt; 230 Vac</i>	<i>up to 60m / 197 ft</i>	<i>4 x 6 mm<sup>2</sup> / 4 x 0.010 in<sup>2</sup> (0.51 kg/m / 0.34 lb/ft)</i>	<i>4 x 6 mm<sup>2</sup> / 4 x 0.010 in<sup>2</sup> (0.51 kg/m / 0.34 lb/ft)</i>	<i>-----</i>
	<i>up to 100m / 329ft</i>	<i>4 x 10 mm<sup>2</sup> / 4 x 0.016 in<sup>2</sup> (0.90 kg/m / 0.60 lb/ft)</i>	<i>4 x 10 mm<sup>2</sup> / 4 x 0.016 in<sup>2</sup> (0.90 kg/m / 0.60 lb/ft)</i>	<i>-----</i>
	<i>up to 150m / 492 ft</i>	<i>4 x 16 mm<sup>2</sup> / 4 x 0.025 in<sup>2</sup> (1.25 kg/m / 0.84 lb/ft)</i>	<i>4 x 16 mm<sup>2</sup> / 4 x 0.025 in<sup>2</sup> (1.25 kg/m / 0.84 lb/ft)</i>	<i>-----</i>
Single phase outlet		120 V / 16 A	230 V / 16 A	230 V / 16 A

### 1.3 Chassis

Dimension A	6880 mm	270.9 in
Dimension B	5630 mm	221.7 in
Dimension C	6878 mm	270.8 in
Dimension D	1710 mm	67.3 in
Dimension E	2320 mm	91.3 in
Dimension F	2040 - 2810 mm	80.3 - 110.6 in
Dimension G	668 - 968 mm	26.3 - 38.1 in
Dimension H	490 - 605 mm	19.3 - 23.8 in
Weight	1480 kg	3256 lb
Tyre pressure	5 bar	72 psi

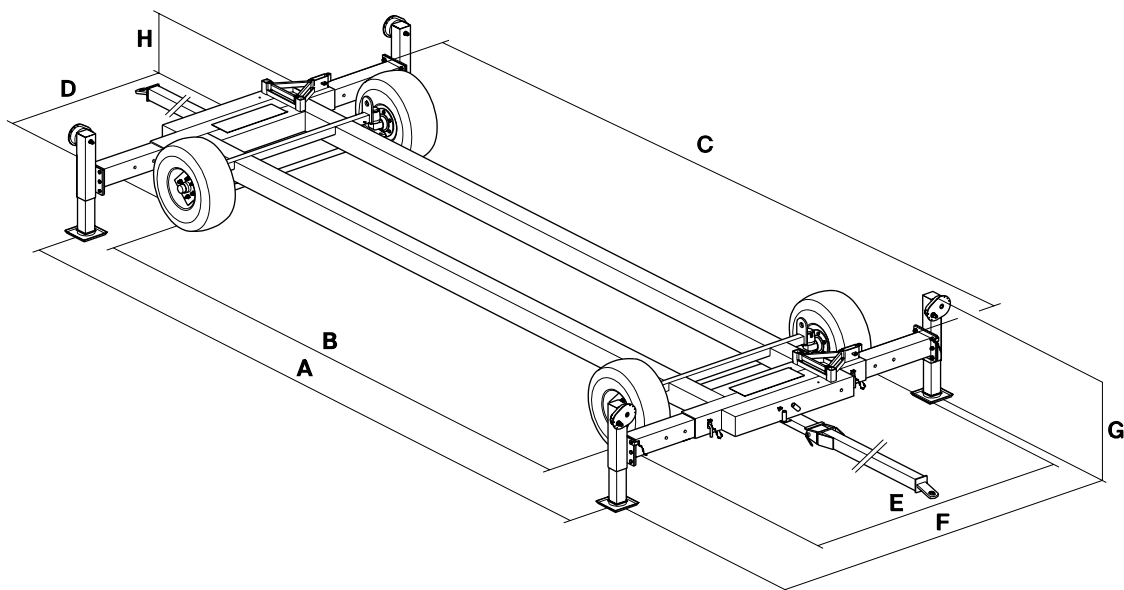

Fig.1-4 Chassis

### 1.4 Platform construction and loading diagram

On any platform element, no more than one platform element of 150 and one platform element of 175 may be attached. The permitted loading situations is described in sections 1.4.1



The payload must be equal distributed on the platform.

#### 1.4.1 Maximum loading

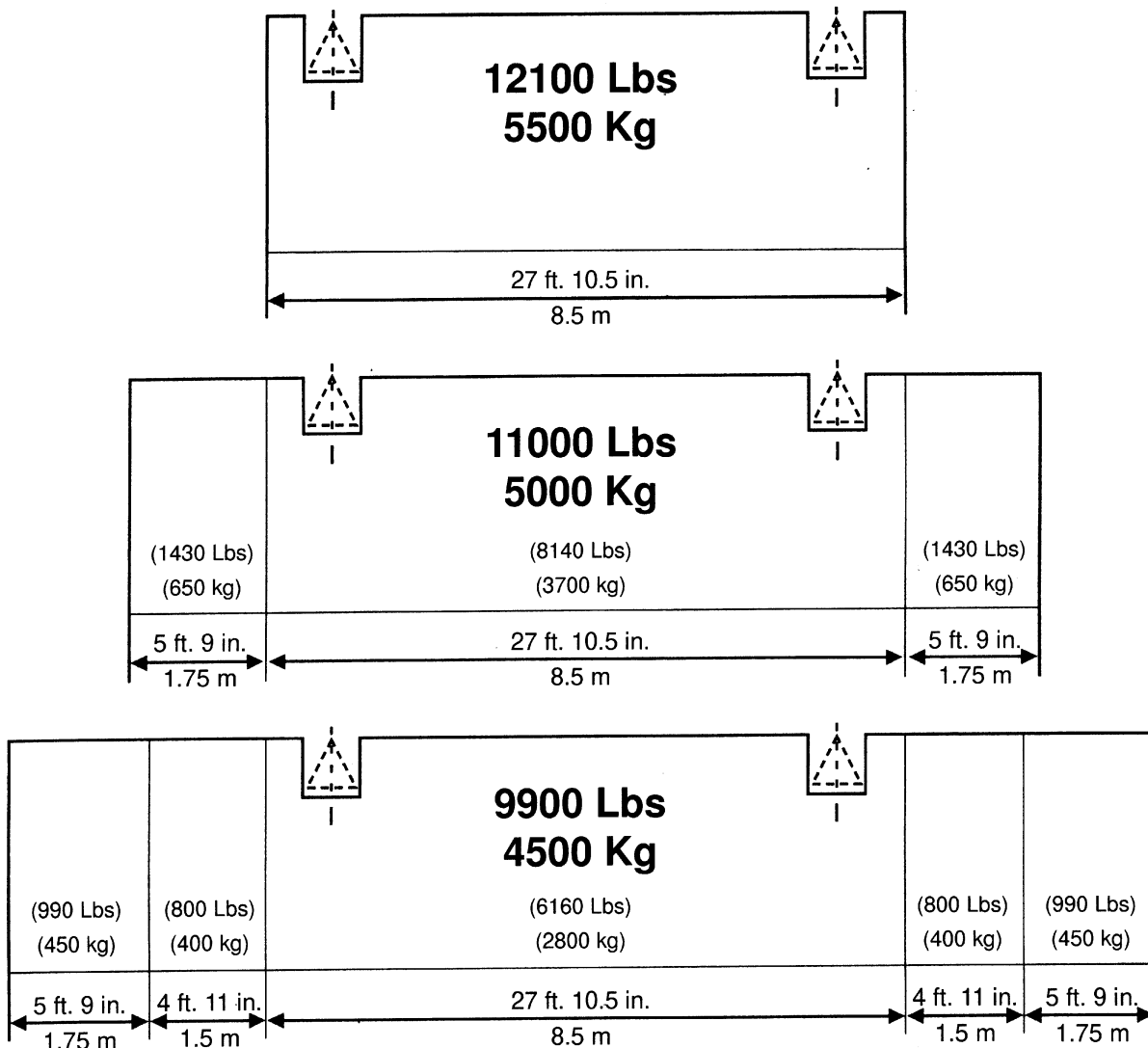

Fig.1-5 Maximum load



## 1.5 Anchor forces

Torque scaffold coupling: 50 Nm / 36.9 lb ft.

The anchor forces are given on page 1.8.

A = Distance mast to facade < 1 m / 3.3 ft

B = Distance between the anchor points on the facade

F1 = Anchor force to its fixation at the facade (perpendicular)

F2 = Anchor force to its fixation at the facade (parallel)

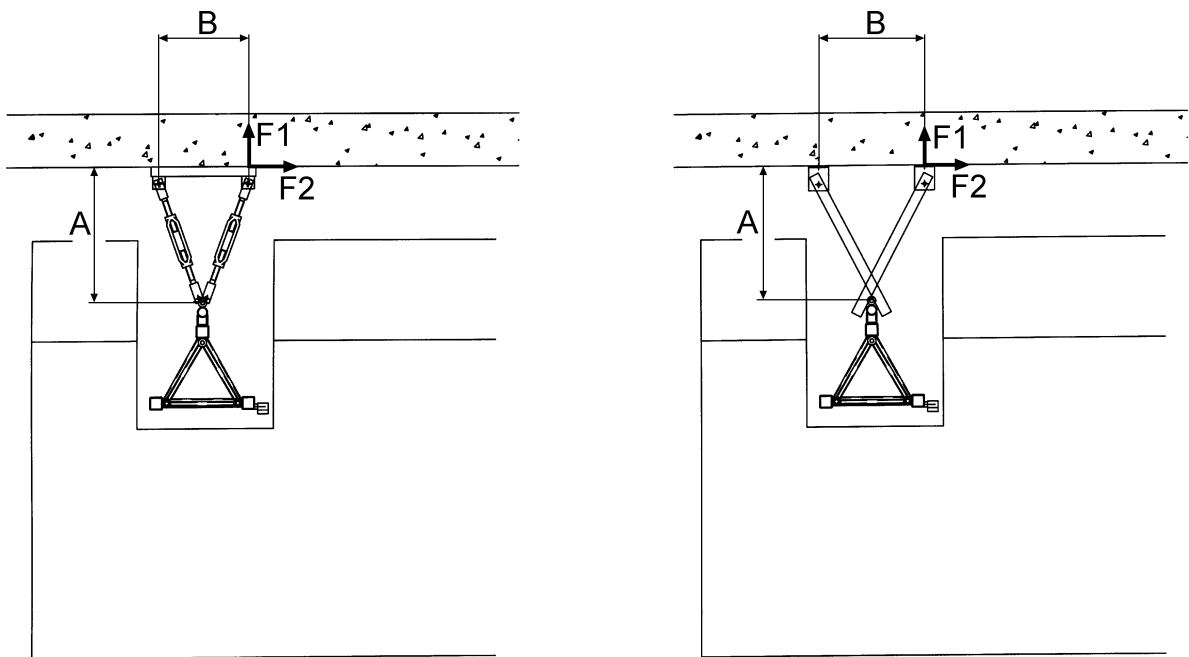

Fig.1-6 Anchor forces



		Ratio A/B*							
		0.5		1		2		3	
		F1 [kN]	F2 [kN]	F1 [kN]	F2 [kN]	F1 [kN]	F2 [kN]	F1 [kN]	F2 [kN]
Mastheight above last anchor = 0m	anchor distance = 6 m	6.1	6.1	7.1	3.6	9.2	2.3	12.2	2.0
	anchor distance = 8 m	5.9	5.9	7.9	4.0	11.9	3.0	15.9	2.7
Mastheight above last anchor = 1/2 anchor distance	anchor distance = 6 m	7.2	7.2	8.7	4.3	11.8	2.9	14.9	2.5
	anchor distance = 8 m	6.7	6.7	8.8	4.4	13.3	3.3	17.9	3.0

\* Ratios may be linear interpolated.

		Ratio A/B*							
		0.5		1		2		3	
		F1 [lbf]	F2 [lbf]	F1 [lbf]	F2 [lbf]	F1 [lbf]	F2 [lbf]	F1 [lbf]	F2 [lbf]
Mastheight above last anchor = 0m	anchor distance = 19.7 ft	1375	1375	1600	810	2070	520	2745	450
	anchor distance = 26.2 ft	1330	1330	1780	900	2680	675	3580	610
Mastheight above last anchor = 1/2 anchor distance	anchor distance = 19.7 ft	1620	1620	1960	970	2655	655	2255	565
	anchor distance = 26.2 ft	1510	1510	1980	990	2995	745	4030	675

\* Ratios may be linear interpolated.

## 2. COMPONENT DESCRIPTION

### 2.1 General description

The basic set of the mast climbing work platform with rack and pinion drive consists of the following 5 main parts:

- \* drive
- \* masts
- \* platform fences
- \* chassis
- \* control system

The platform moves along the mast with the aid of Nylontron rollers.

The motors are fitted with centrifugal brakes which retard the platform if the speed of descent is exceeded.

The platform is driven up and down the mast by means of two electric motors acting through a differential gearbox, each motor having two pinions. The parallel movement of the platform is controlled automatically.

Much consideration has been given to simple and safe assembly and disassembly.

A crane on the platform (option) ensures that the mast elements can be positioned quickly and safely.

The platform can be adjusted to suit the required working situation with the use of separate platform elements. The width of the platform can be adjusted by means of outriggers.

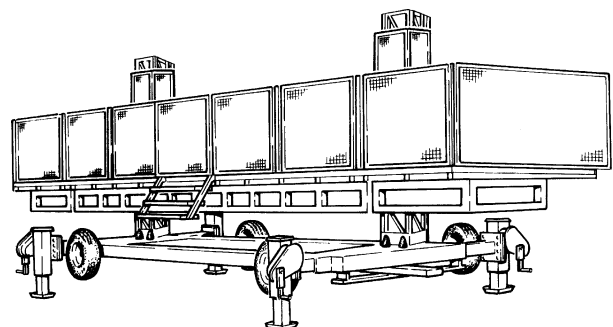

Fig.2-1 Basic set MS 5000

All electrical connections, which must be disconnected for transport purposes, are made by means of connectors.

The electrical installation is mounted inside the control box on the platform.

The simple construction ensures that only a minimum of maintenance is required.

The most elements, the chassis, the platform and various other components are protected from corrosion by means of galvanization or another appropriate surface treatment.

### 3 SAFETY

#### 3.1 General



No changes or modifications may be made to the machine.



The ground surface must be stable to support the weight of the machine and the mast.



The mast must ALWAYS be anchored in accordance with the instructions.



If during assembly and disassembly, the fences do not provide sufficient protection, suitable safety harness must be used at heights above 2 metres.



During use, no person should stand **under** the machine.



While a mast element is being mounted, an anchor is being fitted or while maintenance activities are being carried out, the emergency stop must be active.



Material must never extend beyond the outer limits of the platform. Items which may roll must be properly secured. Materials must never be stacked against the fencing.



If work must be carried on close to high voltage cables, a minimum safety distance of 15 m (49.2 ft) must be maintained.

#### 3.2 Safety prior to use

- The chassis must be effectively supported.
- The working area around the machine must be free from obstacles.
- The machine must be securely anchored at the specified intervals.



When materials and/or tools with a large surface area will be used contact your mast climbing work platform supplier in connection with wind sensitivity.

#### 3.3 Safety in use



At wind speeds above 12.5 m/s (41 ft/s, 6 Beaufort) by a freestanding machine or 15.7 m/s (51.5 ft/s, 7 Beaufort) by an anchored machine, the machine must not be used and the platform must be set in the lowest position.



When electrical storms are expected, work on the platform must be stopped in time to avoid the danger of lightning strikes. The power supply must be switched off and the connector withdrawn from the supply socket.



There must be no obstructions in the path of the machine.

- If the machine is to be used during the hours of darkness, the area must be adequately lit, so that the user has a good view in all conditions. A minimum brightness of 50 lux at control box height is required.
- The working area must be kept free from obstacles (building materials, dirt, snow, etc.).
- The machine may only be used for the purpose for which it was designed, that is, the vertical transportation of persons and materials with a maximum weight within the design limits of the particular construction.
- Loads (materials, persons, etc.) must be distributed in accordance with the loading diagram.
- Inspection and maintenance must be carried out as given in this instruction manual.
- During assembly and maintenance, the mast climbing work platform may not be used for other purposes.
- Local safety laws and regulations must always be followed.
- Fences must never be removed during normal use.
- The platform must only be entered from one parking position only. The same rule applies to leaving the platform.
- Keep hatches in the base of the platform clear. From the platform it must be possible to get to the emergency descent controls via the hatches.
- In order to ensure that no person unintentionally walks under the platform and to protect persons against falling objects, the mast climbing work platform must be surrounded with suitable fencing and/or a marking wire. The marking must be placed at a distance of at least 0,5 m (19.7 inch) from the mast climbing work platform.
- Platform extensions on outriggers may only be used to carry personnel. Such personnel may only stand on these extensions when the machine is stationary.
- It is not allowed to climb into the mast of the mast climbing work platform.
- If erecting two adjacent platforms there must be a clear gap between the ends of the platforms of at least 0,5 meter (17.5 inch).

### 3.4 Safety after use

- Transport on public roads must only be done with a truck intended for the purpose.
- The platform must be placed in its parking position and the main switch must be secured with a padlock to avoid unauthorised use.

### 3.5 Built-in and additional safety features

The MS 5000 mast climbing work platform is provided with the following in-built and additional safety features:

- Phase control relay in the control box. Controls the phase sequence of the power supply.
- Emergency stop push button on the control box. When this button is pressed the platform is locked.
- Electrical access protection. When the access gate is open the platform is locked.
- Centrifugal brakes ensure a controlled descent in the event of an emergency.
- In the event of a power failure the motor brakes are operated automatically to prevent the platform from descending unexpectedly.

- In the event of a power failure it is possible for the platform to make an emergency descent by manually releasing the motor brakes.
- Audio Visual Warning. During descent of the platform, a buzzer will sound and a light will flash underneath the platform.
- If the TOP limit switch fails to operate, so that the mast climbing work platform continues to rise, an additional emergency limit switch is operated.
- If the LOWER limit switch fails to operate, so that the mast climbing work platform continues to descend, an additional emergency limit switch is operated.
- If the TOP limit switch and the emergency limit switch fail and also the red topmast is not mounted, so that the mast climbing work platform continuous to rise, the drive unit will rest on the safety hooks.
- Two proximity switches are mounted on the platform to prevent the platform rising above the mast during assembly.

### 3.6 Personnel

- Operations on the mast climbing work platform may only be carried out by persons who have reached the age of 18 years.
- Operations on the mast climbing work platform may only be carried out by persons who have the approval of the owner or the responsible person.
- Operations on the mast climbing work platform may only be carried out by persons with adequate knowledge and qualifications to do so.
- The competence and sense of responsibility of the operator or engineer are essential to the efficient and safe use of the platform.
- Technical personnel must be instructed and be familiar with this manual.
- Technical personnel must be in a position to deal with any difficulty encountered in every possible situation during assembly and disassembly. The operating personnel must be familiar with those situations which can occur during use.
- There must always be two persons present on the platform during use. This is required in case it is necessary to make an emergency descent.
- If operating or technical personnel report errors or dangers or are not aware of the safety regulations, the owner or the person responsible must be informed immediately.
- Work on the electrical systems may only be carried out by a qualified electrician.
- Personnel protective equipment such as a hard hat, safety shoes, tight-fitting clothes must be used.





#### 4 TRANSPORT



Transportation on the chassis over the public roads is not permitted.



The national valid traffic regulations must be observed.

Because of its limited dimensions, the basic implementation of the machine can be transported with a normal lorry. Ensure that, during transport, all securing devices are properly fitted and that the machine is lowered onto the buffers.

Disassemble the machine before transporting it as described in chapter 8.

For the transport dimensions, see chapter 1.

For transport, all fences, steps and mast protection must be removed. These components may be lashed firmly to the platform.

For transportation, secure the machine carefully onto the loading platform of the transport vehicle.

The machine can be loaded and unloaded from the transport vehicle using a crane mounted on the vehicle, a crane on the building site or a fork-lift truck. See figure 4-1 for loading and unloading points.

Set the machine down carefully to avoid damage.

See figure 4-1

A lifting point.

B Support points for the fork of a fork-lift truck (under the platform, with the forks placed as far apart as possible).

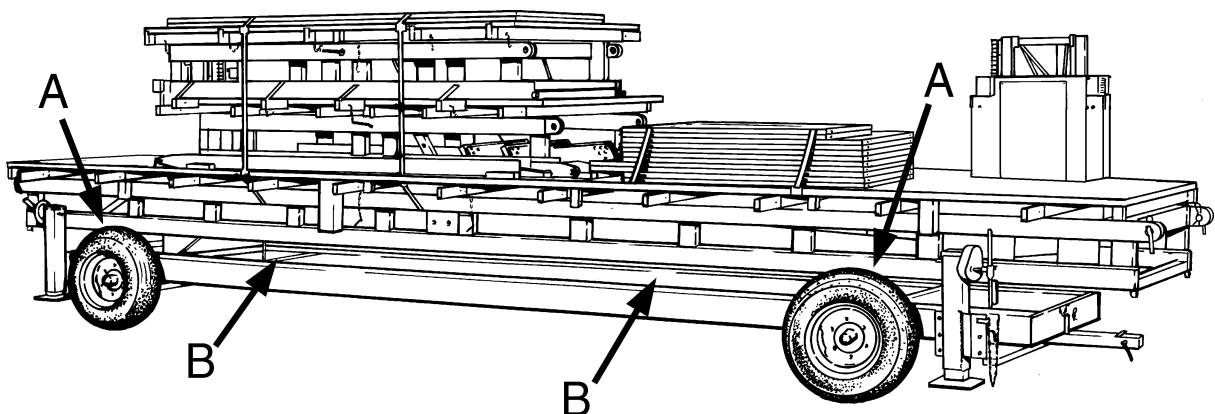

Fig.4-1 Transport MS 5000

#### 4.1 Repositioning on the building site



Ensure that trees, power cables etc., cannot be touched.



During movement there may be no load on the platform.

Once on the building site, the mast climbing work platform can be moved in the lowest position on its chassis.

The plug of the power supply must be removed.

On a hard flat horizontal surface and when there is no wind, the mast may have a maximum height of 8 m / 26.3 ft during repositioning. The platform must be on the buffers. The legs must be set out and secured. The jack must be screwed out until they are just clear the ground.

When the circumstances are unfavourable than the above mentioned circumstances, contact your supplier.

The chassis can be moved behind a vehicle.

The maximum speed at which the chassis may be towed behind a vehicle is 30 m/min / 98.4 ft/min.

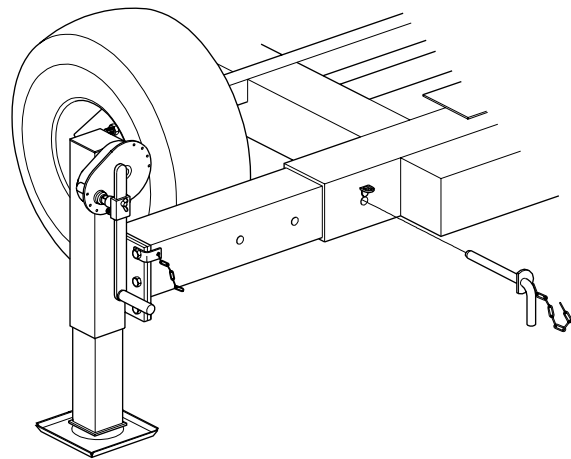

Fig.4-2 Locking pin outrigger chassis

## 4.2 Repositioning with a crane



During movement there may be no load on the platform.

At the building site the mast climbing work platform can be repositioned with a crane under the following circumstances.

A maximum of 4 mast elements may be mounted on the chassis or the ground frame. The eye hooks of the crane can be attached to lifting points of the chassis.

The total transport weight can be calculated on the undermentioned way.

No. of basic machines	x 4500 kg / 9713.0 lb =	
No. of platform elements 150	x 198 kg / 435.6 lb =	
No. of platform elements 175	x 205 kg / 451.0 lb =	
No. of mast elements 150	x 86 kg / 189.2 lb =	
No. of plug-in fences 150	x 16.2 kg / 35.6 lb =	
No. of plug-in fences 175	x 18.2 kg / 40.0 lb =	
No. of end fences	x 32 kg / 70.4 lb =	
No. of gates	x 17.1 kg / 37.6 lb =	
No. of lengthwise posts	x 3.2 kg / 7.0 lb =	
No. of gate side posts	x 3.4 kg / 7.5 lb =	
No. of end fence posts	x 4.0 kg / 8.8 lb =	
		_____ +
Total transport weight	=	kg / lb



## 5 CONTROL COMPONENTS

### 5.1 Power supply socket for the platform

The power supply cable for the electrical supply between the building site connection and the mast climbing work platform must be connected to the socket. The connection socket is positioned in the centre of the platform. See chapter 1 for the cable specifications.

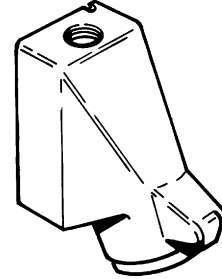

*Fig.5-1 Platform power supply socket*

### 5.2 Single phase outlet

On the machine a single phase outlet is fitted. This outlet can be used for electrical tools, lightning etc.

### 5.3 Platform control box

The door of the control box is secured with two quick-release fasteners.

The control box is provided with the following control components:

1. Main switch.

This switch is used for activating power supply. This switch may not be used for stopping the machine.

The main switch shall be secured with a padlock to prevent unauthorized use of the platform.

2. Info panel.

This information panel consists of a display on which error codes appear, if an error is detected.

3. Push button UP.

When this push button is pressed, the platform rises.

4. Blue control light.

This light will illuminate when the electric safety circuit (gates etc.) is closed.

5. Push button DOWN.

When this push button is pressed, the platform descends.

6. Emergency push-button.

If this push button is depressed, the lifting platform is "locked" in position.

When the Emergency push-button is pressed it is locked in the depressed position. It can be unlocked by rotating it.

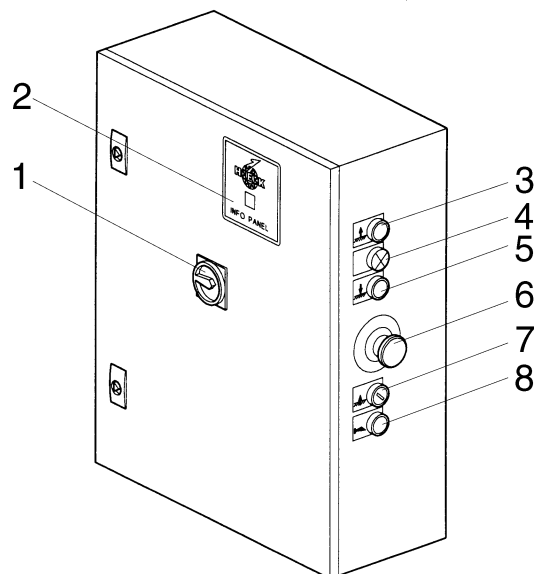

Fig.5-2 Control box

7. Keyswitch buffer.  
In position 1 the platform can be raised out of the buffer
  
8. Horn.  
When this button is pressed a horn will sound.

The following components are mounted in the control box:

- the main switch
- the safety relay
- the control relay
- the transformer
- the automatic fuses





## 6. ASSEMBLY AND ANCHORING

This chapter describes the assembling and anchoring of the mast climbing work platform. The definition of left and right in relation to positioning is the following:

Left-hand: Viewed from the step side, the machine is fitted to the left-hand side.

Right-hand: Viewed from the step side, the machine is fitted to the right-hand side.

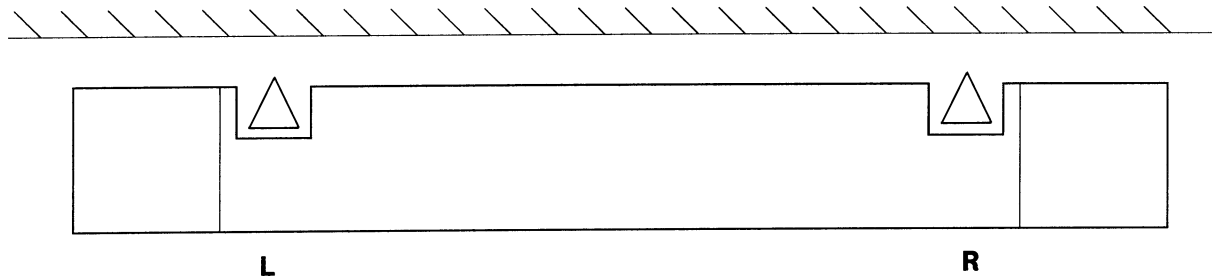

Fig.6-1 Position machine



If assembly work must be interrupted, this must be done in such a way that, when the work is restarted it is clear what stage had been reached when work was stopped. For this reason always complete a part of the assembly, for example, assemble collect or secure all the components for a connection, complete a ground support or completely assemble an anchor before stopping work.



**Only components marked, as 5 L resp. 5 R, may be mounted (chassis, platform, mast elements and platform elements).**

While the mast is being erected, no more than two persons may be on the platform, so that no more than 75% of the lifting capacity is used.

The assembly must always be followed by a test run, as described in section 7.3. Until the test has been performed, the platform may not be used for any purpose other than transporting its own mast elements and anchoring components.

The loading of the mast climbing work platform must be planned so that when an anchor must be fitted (the maximum distance between anchors is reached), the material load on the platform is a minimum.

## 6.1 Preparation for assembly



Ensure that the site where the mast climbing work platform will be assembled accords with the national requirements and that permission has been obtained from the relevant authorities for the assembly.

- Ensure that a suitable power supply, good lighting, lifting equipment and tools are available.
- Ensure that the building site is easily accessible to the vehicle which will deliver the mast climbing work platform.
- Prepare the site with suitable support and anchoring facilities.
- Ensure that the position where the mast climbing work platform will stand has good drainage.
- Plan the positioning of the mast climbing work platform so that where the mast needs to be anchored, it can be so anchored with the standard material.
- The components of the mast climbing work platform mast should be placed as close as possible to the place where it will be assembled.
- The electrical power supply connection must be placed as close to the mast climbing work platform as possible so as to reduce the voltage drop to a minimum. If the voltage reduction is too great the machine may not function correctly.

## 6.2 Ground support



The machine must always have a support underneath the jacks.

The ground support and the soil must meet the following requirements:

- Ensure that the forces are spread over as large an area as possible.
- The soil must be able to withstand a ground pressure of at least  $2 \text{ kg/cm}^2$  /  $30 \text{ lb/in}^2$ . If this requirement is not met, soil improvement must be carried out such that the ground satisfies this minimum requirement.
- The ground support must be flat and centrally loaded with a minimum ground support of  $400 \times 400 \text{ mm}$  /  $15.7 \times 15.7 \text{ in}$ . See fig. 6-2.
- The ground support must be able to withstand a pressure of at least  $20 \text{ kg/cm}^2$  /  $300 \text{ lb/in}^2$ .
- The platform must be supported with suitable ground support placed under the extended outriggers on the chassis (see fig.6-2). If the height of the mast exceeds 20 metres / 65.6 ft, ground support must also be placed under the mast.
- The ground support must be durable and of such a quality that the load can be transferred without plastic deformation.
- If the machine is installed on a concrete foundation or on a hard road surface, the installation must be provided with wooden packing to prevent slipping.

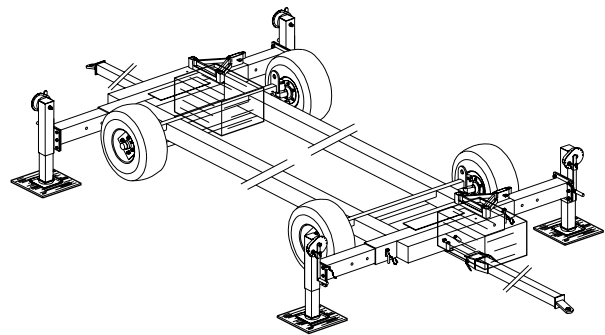

Fig.6-2 Ground support chassis

### 6.3 Positioning the mast climbing work platform general



A fence (height 1.10 m / 43.3 in) completely surrounding the platform is compulsory. If the distance between the platform and the facade is 0.3 m - 0.5 m (11.8 in - 19.7 in) in a fence with a height of 0.7 m (27.6 in) can be used. If the distance between the platform and the facade is less than 0.3 m (11.8 in) a fence is not compulsory but in this case a kick board with an height of 0,15m (5.9 in) must be fitted.



Wheels of the chassis should not have a bearing function while assembly and operating the platform.

Distance to the facade with standard anchoring.

A = 726 - 916 mm (28.6 - 36.1 in)

B = 526 - 716 mm (20.7 - 28.2 in)

C = 200 mm (7.9 in)

There are two ways in which the mast climbing work platform can be placed:

- freestanding on chassis
- anchored on chassis

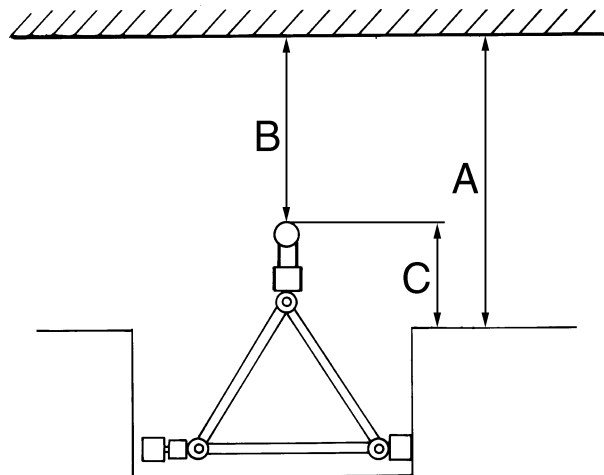

Fig.6-3 Distance to the facade

### 6.3.1 Positioning the mast climbing work platform

1. Position the chassis parallel to the wall.
2. When the construction is to be free-standing, the outriggers must be fully extended and secured in position. For an anchored construction, it is possible to leave the outriggers in the retracted position. In this situation the outriggers must be properly secured and the first anchor must be placed at a height of four metres.
3. Place the ground supports.
4. Unscrew the jacks until the wheels no longer contact the ground and adjust the machine to level. The measurement must be done on two sides of the mast with a spirit level with a minimum length of 1 meter (40 inch).
5. Check that the lower striker plate is mounted. See fig.6-5.
6. Assemble the platform components sequentially on both sides until the desired length is attained. The platform may not exceed the maximum length.
7. Secure the platform pins by means of "hairpins". See fig.6-6.
8. Adjust the platform elements so that they are horizontal with the aid of the adjusting bolts on the underside of the platform.
9. The width of the platform can be adjusted to fit the form of the façade. See section 6.6.

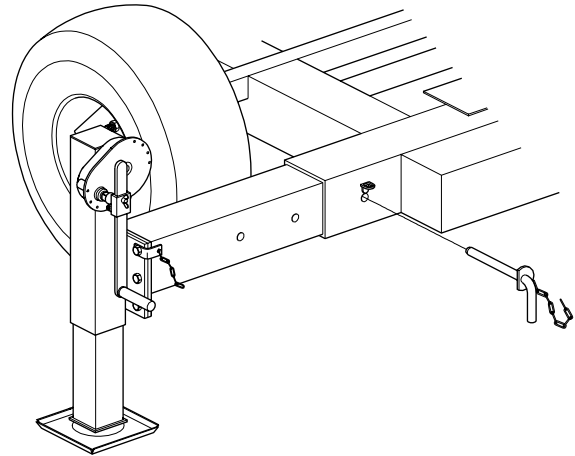

Fig.6-4 Locking pin outrigger chassis

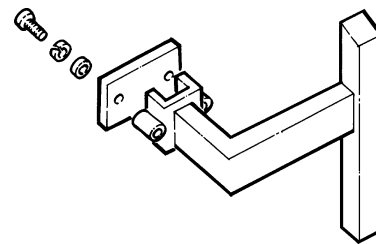

Fig.6-5 Lower striker plate

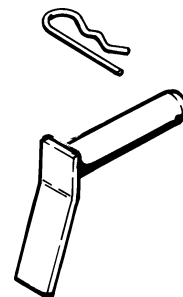

Fig.6-6 Securing platform elements

10. Mount the steps and secure them with locking pins. See fig.6-7.
11. Mount the platform posts on the upper side of the platform and secure them with "hairpins".
12. Mount the posts for the gate on the longer side of the platform and secure them with "hairpins".
13. Mount the platform posts on the longer side of the platform and secure them with "hairpins".
14. Mount the fencing and secure it with "hairpins".
15. Mount the gate and check that the gate safety switch is present on the underside of the platform.

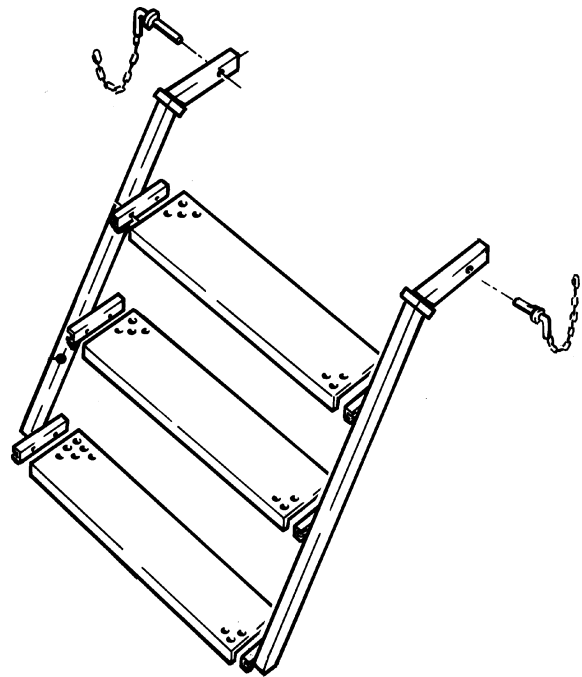

Fig.6-7 Locking pin step

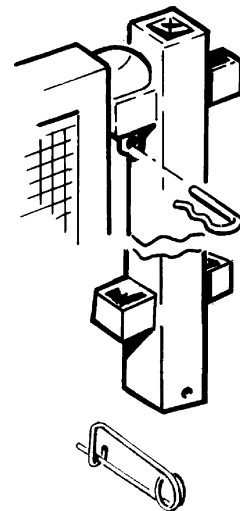

Fig.6-8 Securing platform posts and fences

## 6.4 Assembly of the mast



If work has to be stopped, always complete the phase being worked on. Tighten all the bolts used for the last attachment and switch off and secure the main switch so that the machine cannot be operated.



As the assembly proceeds, place the anchor tubes and anchors as described in section 6.5



Note that the power supply of the building site is corresponding with the electric design of the machine.



The masts must always be assembled vertically.



In winds of strengths above 6 Beaufort (12,5 m/s) (41 ft/s) the machine may not be assembled.



While a mast element is being mounted, the emergency stop switch must be activated.

1. Connect the power supply to the machine. The power supply connection is in the centre of the platform.
2. Set the main switch in position I or II (the position depends on the direction of phase rotation of the power supply). If the display shows code 02 set the main switch in the other position. The display must show code 00 and the phase light will be burning.

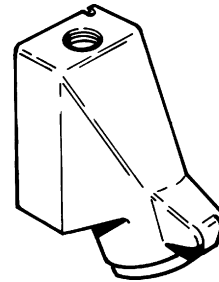

Fig.6-9 Power supply socket

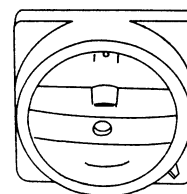

Fig.6-10 Main switch

3. When the mast climbing work platform is delivered it is in the buffer. In order to remove the mobile work platform out of the buffer, carry out the following procedure:

1. Press the push-button "reset positioning" (fig.6-11, A) and keep it pushed in.
2. Press the push-button "UP" (fig.6-11, B).

4. The mast climbing work platform is raised and lowered by pressing the UP and DOWN push buttons. When the push-button is released, the mast climbing work platform stops. In addition, an emergency stop push-button is provided. When this button is pushed, the power of the motors will be shut off.

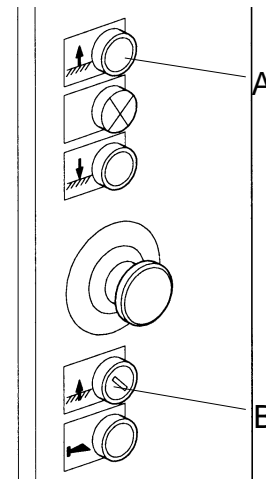

Fig.6-11 Control buttons

5. Check that the proximity switch is mounted. See fig.6-12.

6. Load the platform with mast elements. Using a fork-lift truck or crane if necessary. Ensure that the maximum loading permitted during assembly is not exceeded.

7. Stand on the platform and place a mast element on the last element assembled using the crane if required. Secure the mast element with four bolts, washers and nuts. Tighten the bolts with a torque wrench to the specified torque (See chapter 1).

If a crane is available on the building site, the mast can be more quickly assembled. Up to four mast elements can be assembled on the ground and then raised into position with the crane.

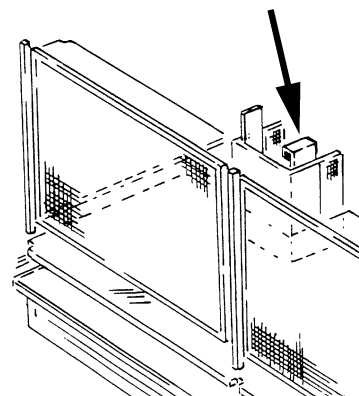

Fig.6-12 Proximity switch



8. Mount the first anchor. See section 6.5.
9. Raise the platform towards the top of the mast element and repeat the procedure until another element must be assembled. Plan the procedure so that, when an anchor must be fitted, the loading of material and mast elements is a minimum.



Ensure that anchors are placed at the specified intervals.

10. Repeat this working method until the mast has reached the required height. Finally, the mechanical end stop must be attached to the left-hand mast. The maximum specified height must not be exceeded.
11. Mount the mechanical endstop on the mast.
12. The mast must not extend too far above the uppermost anchor (See chapter 1). To achieve good stability, it is always better to place an anchor as close to the top of the mast as possible.
13. Assemble the mast guards from the platform and secure them.
14. The assembly is now complete. The assembly must now be tested as described in section 7.2 and 7.3.

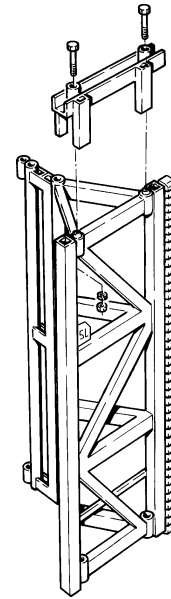

Fig.6-13 Mast element with mechanical end stop

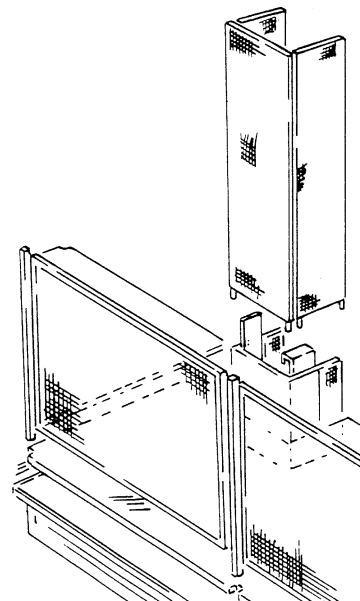

Fig.6-14 Mast cover

## 6.5 Anchoring the mast



If work must be stopped, always complete the current phase before stopping. Tighten all the bolts for the latest fixture and secure the main switch so that the mast climbing work platform cannot be operated.



Before starting to fix any anchors, ensure that the chassis is level.



The wall must be of such a quality that it can accept the forces applied to it via the anchors.



The platform extensions and the anchors must not come into contact during raising and lowering.



While a mast element is being mounted, the emergency stop switch must be activated.

The anchor forces must be approved by the owner or the person responsible for the building to which the machine will be anchored.

1. Check that each mast is vertical with a spirit level at least one metre long. Recheck as each anchor is secured.
2. The mast must be anchored to the building at the distances specified in chapter 1.
3. The anchors consist of horizontal anchor tubes with a stretcher arrangement, mast couplings and a wall plate.

4. Fixing the anchors:
  - If conditions make it necessary, use may be made of other approved attachment materials which are suitable for the forces present. (Consult your dealer).
  - Cemented-in anchors must be allowed to become fully secure (the cement must have time to harden) before the mast climbing work platform is assembled. The cement or concrete used must be in accord with the specifications.
  - If chemical anchors or expansion bolts are used, these must be approved and must be able to withstand the forces involved.
  - Specifications for these types of bolts are available from the supplier. Permission to use them must be obtained from the local authorities.
  
5. Securing an anchor:
  - Attach the coupling to the mast (1). Do not tighten it fully yet.
  - Attach the wall plate (2) to the building.
  - Secure the horizontal anchor tubes with stretcher arrangement (3) between the coupling on the mast and the wall plate.
  - Tighten the bolts securing the coupling to the mast and all the remaining bolts on the anchor with the correct torque loading.
  - Adjust the stretchers so that the mast is vertical and equidistant from the building.
  - Tighten the locking nuts (4) on the stretcher arrangement.

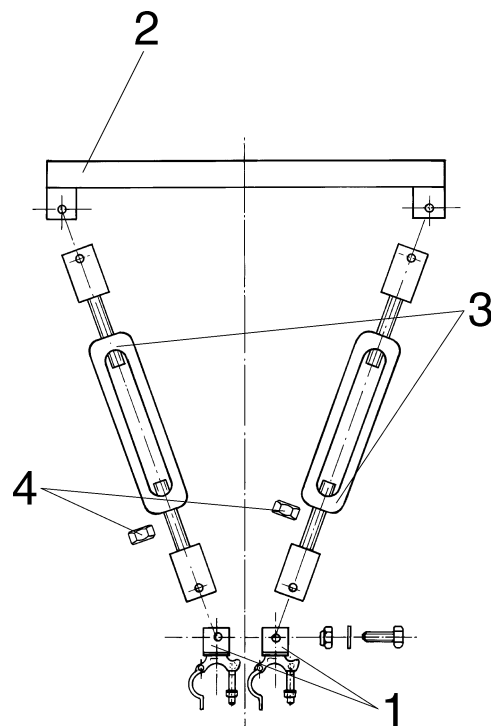

Fig.6-15 Anchor

## 6.6 Adjusting the platform width

The width of the platform can be adjusted to the shape of the building. As standard an extension of 1 metre is possible. In addition, there is a possibility to position the extension 46 cm (18.1 in) lower. Adaptor tubes must then be mounted at the height of the motors and the mast.

In case work must carry out behind the mast an anchor ramp must be mounted.



The planks used for adjusting the platform must in every case be secured in every direction.



The platform widening and the mast anchors must not come into contact when the platform is raised and lowered.



A fence (height 1.10 m / 43.3 in) completely surrounding the platform is compulsory. If the distance between the platform and the facade is 0.3 m - 0.5 m (11.8 in - 19.7 in) a fence with a height of 0.7 m (27.6 in) can be used. If the distance between the platform and the facade is less than 0.3 m (11.8 in) a fence is not compulsory but in this case a kick board with an height of 0,15m (5.9 in) must be fitted.

The platform extension must be fabricated from a non-slip, easily cleaned material. The extension must be self draining.

The width of any openings or gaps in the floor must be sufficiently narrow that a ball with a diameter of 15mm / 0.6 in will not pass through.

The platform extension must be able to withstand a static load of 200kg (440 lb) on an square area of 0,1x0,1m (0.4x0.4 in) on the least favourable part of the floor surface without causing any permanent distortion.

1. Pull out the outriggers to the required height and secure them with locking pins. See fig.6-16.
2. Cover the outriggers with planks.
3. Fix cross strips or a right-angle profile to the underside of the planking and secure them to the outriggers.
4. Mount the anchor ramp (fig.6-17) to the outriggers.

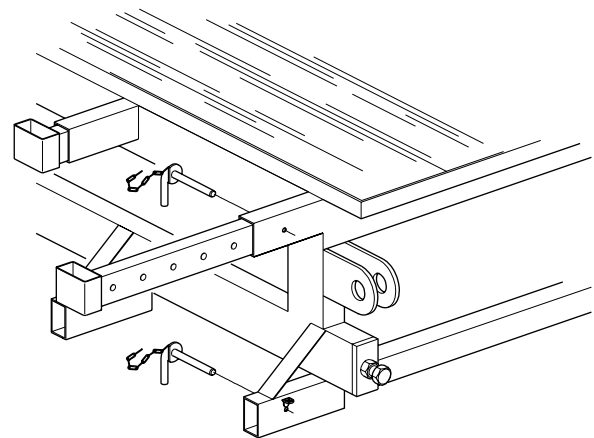

Fig.6-16 Outrigger platform extension

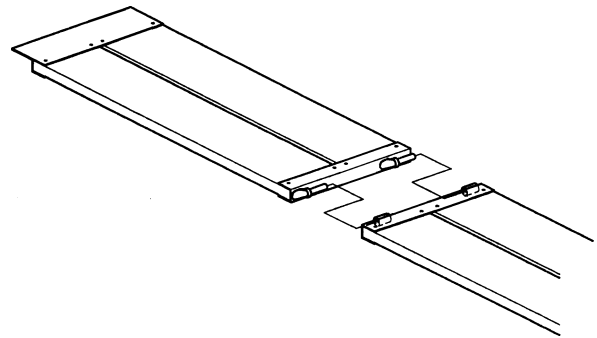

Fig.6-17 Anchor ramp

## 6.7 Lightning protection

1. Mount the connection between the chassis and the earth. This connection must satisfy the following specification:  
 DIN VDE 0185, part II, §5.2  
 The cable supplied (25 mm<sup>2</sup> / 0.039 in<sup>2</sup> cross section, 25 m / 82ft long) must be connected to the terminal box on the building site.

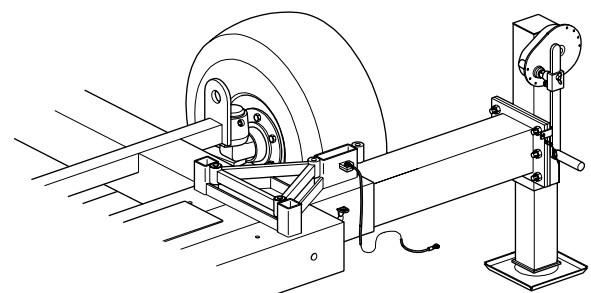

Fig.6-18 Lightning protection



## 7. OPERATION

### 7.1 General



No person may stand under the machine while it is in use.



Material may never extend beyond the edges of the platform. Items which can roll must be properly secured. The load may never be supported against the fencing.

The maximum reaction force (for instance caused by tools) of the platform with regard to the facade amounts 800 N (180 lbf).



When work stops for any reason, the main switch must be secured with the padlock.



During raising or descending no person may stand on the platform extensions.



Do not step on the wheels.

### 7.2 Preparation

1. Before the mast climbing work platform is used it must be visually inspected (daily if it is used every day) for:
  - anchors
  - presence of all security devices
  - connection between mast elements
  - position of the masts
  - any loose components

- ground supports and the quality of the ground
- electrical connections
- protective covers (presence and securing)
- securing of the platform extension
- operation of the limit switches
- no obstacles in the path of the platform
- oil leaking from the drive units
- functioning of the motor brakes (section 7.4).

2. Connect the electrical power supply.

3. Close the gate.

4. Remove the padlock from the main switch.

5. Place the main switch in position I or II (the position depends on the direction of phase rotation of the power supply)

6. Check that the EMERGENCY push-button on the control box is switched off (the push-button must be pulled out).

7. If the display shows code 02 , the main switch must be set in the other position. The display will show code 00. If the electric safety circuit (gates, etc.) is closed the blue light on the control box will burn.

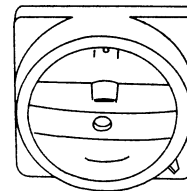

Fig.7-1 Main switch

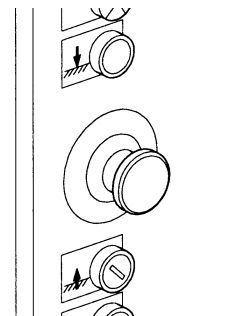

Fig.7-2 Emergency push-button



### 7.3 Testing

1. Test the platform and check the following:
  - all limit switches, striker plates and safety devices and ensure that everything is properly adjusted.
  - that the path of the platform is not obstructed.
  - the functioning of all the push buttons on the control box.
  - the free movement of the power supply cable.

Also test the platform brakes! (see section 7.4)

2. After erection or relocation perform all inspections as described in the appendix: Checklist mast climbing work platform type C.

### 7.4 Brake test

The brake test must be carried out daily.

1. Release the brake on one of the motors by pulling the lever on the motor. The platform should not descend. Release the brake lever.
2. Release the other brake. The platform should not descend. Release the brake lever.



If the platform descends, the mast climbing work platform must not be used. Consult the service engineer.

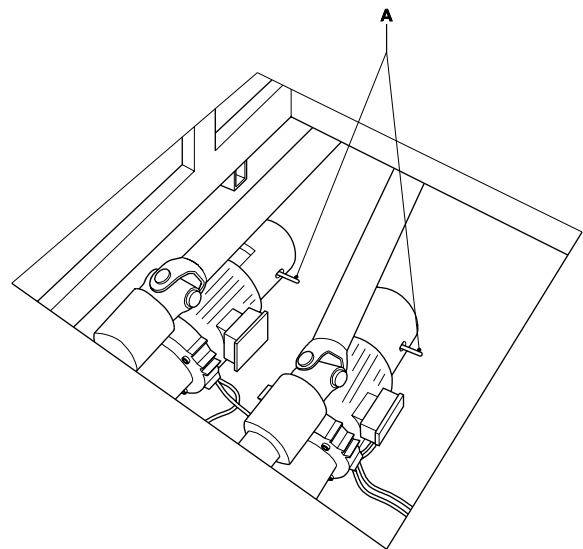

Fig.7-3 Brake lever platform

## 7.5 Operation from the platform

**UP:** If this push-button is pressed, the platform is raised. When the push-button is released, the platform stops immediately.

**DOWN:** If this push-button is pressed, the platform is lowered. When the push-button is released, the platform stops immediately.

**EMERGENCY:** When this push-button is pressed, the platform is locked.

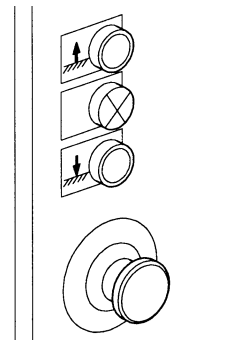

Fig.7-4 Push-buttons control box

## 7.6 Operation in an emergency situation

In an emergency, for example in the event of a power failure, the platform can always be lowered.

- Using the malfunction analysis in chapter 10, try to solve the problem. If the problem can not be solved it is possible to make a emergency descent in the following way.

1. Open the trap door in the platform.
2. Each motor is provided with a lever with which the motor brake can be released (A, Fig.7-5).
3. When these levers are operated, the platform will begin to descend.

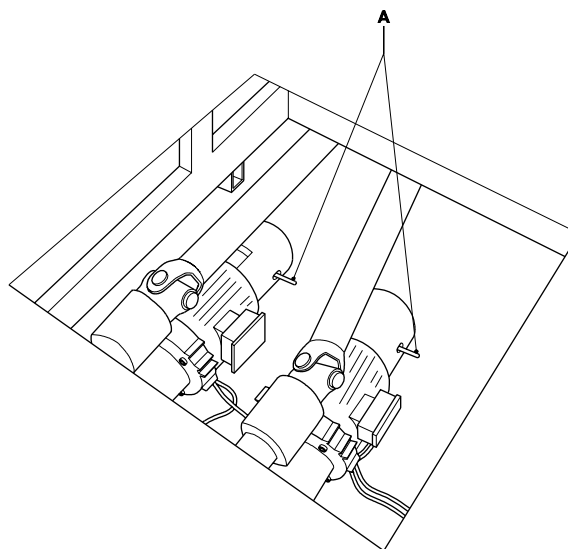

Fig.7-5 Brake lever platform

The speed of descent will be limited by the centrifugal brake.



After a maximum descent of 5 metres (16.4 ft), stop the platform for 2 minutes in order to avoid the centrifugal brakes becoming overheated, which will result in their working less efficiently.



## 8. DISASSEMBLY AND TRANSPORT



Ensure that the maximum loading allowed during assembly is not exceeded.



In winds of strengths above 6 Beaufort (12,5 m/s) (41 ft/s), the machine may not be disassembled.



Never remove any intermediate anchor.



Never remove an uppermost anchor unless the mast above the anchor is disassembled and the platform is unloaded.

1. Remove the mast guards.
2. Disconnect the uppermost anchor.
3. Together with the disassembly of the mast, the anchor tubes and the anchors must be disassembled.
4. If a crane is available on the building site, the mast can be more quickly disassembled. As many as four mast elements can be removed together and lowered to the ground with the crane. The mast elements can further disassembled on the ground.
5. Repeat this procedure until the mast, with the platform in its lowest position, has been completely disassembled.
6. Release the brakes and allow the platform to descend onto the buffers (A, Fig 8-1).

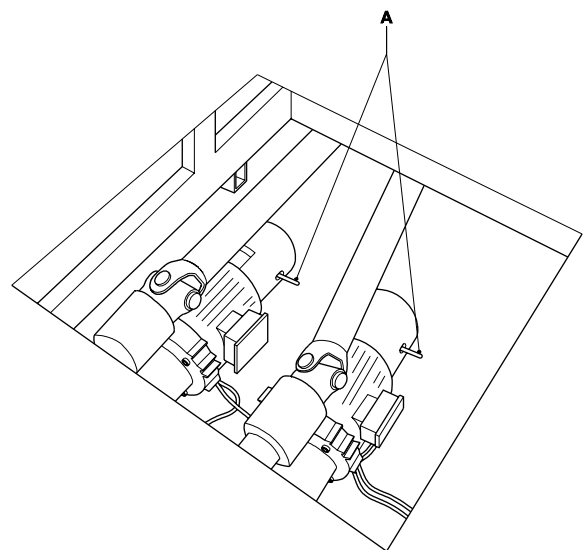

Fig.8-1 Brake lever platform

7. Disconnect the electrical supplies.
8. Raise the jacks and remove the ground supports.
9. Remove the control box.
10. Remove the step

There are two possible ways to transport the basic machine. This can be done with or without the platform elements being attached. The transport method depends on the dimensions of the platform and the widths and lengths of vehicles permitted by national regulations.

If the basic machine is too large to be transported in one piece, take the following steps.

11. Disassemble the fencing, the fence posts, the access gate and the gateposts.
12. Disassemble the platform extensions. Slide in the outriggers and secure them.
13. Disassemble the platform elements.
14. Slide in the outriggers of the chassis and secure them.

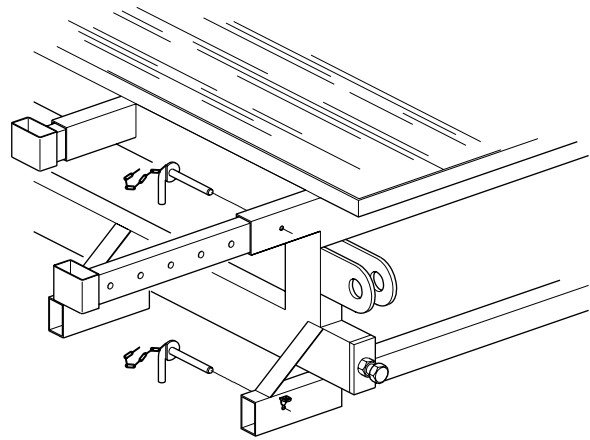

Fig.8-2 Locking pin outrigger

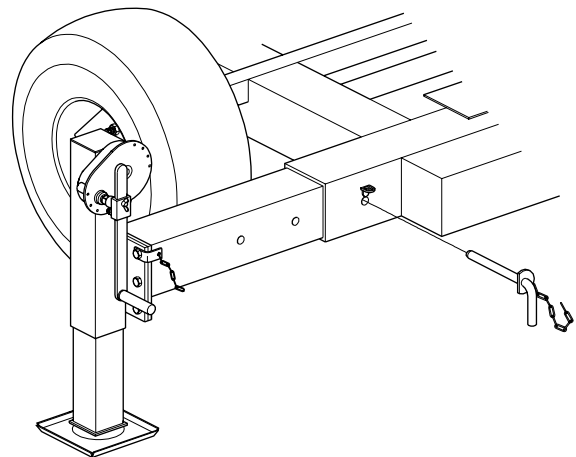

Fig.8-3 Locking pin outrigger chassis

## 9. MAINTENANCE

### 9.1 General

The simple robust construction of the machine ensures that maintenance can be kept to a minimum. Sensible use of the machine, regular checks for correct functioning and regular cleaning will result in a minimum requirement for maintenance. This will guarantee a long working life for the mast climbing work platform.



Maintenance on the mast climbing work platform may only be carried out by persons with adequate knowledge and qualifications to do so. Preferably by qualified persons from the manufacturer or the dealer.

Parts must comply to the technical specification of Hek Manufacturing b.v.!\nUse only original parts of Hek Manufacturing b.v.



Before maintenance is carried out:

- Switch off the main switch (The main switch having been switched off, there still remains voltage on the parts marked with  ).
- remove the power supply socket
- lower the platform onto the buffers.

### 9.2 Maintenance intervals

The following maintenance activities are essential:

After erection or relocation

- Perform all inspections as described in the appendix: Checklist mast climbing work platform type C.

Daily inspection

- The daily inspection is described in chapter 7.2 & 7.3.

#### A. Weekly maintenance

- Grease the rack and pinion. If these are heavily contaminated with sand or grit they must be cleaned first.  
Specification for grease:
  - HEK-rack and pinion grease
  - Shell Rhodina 2
- Clean the platform and the drive units.
- Visually inspect the rack and pinion drive (pitting).
- Perform the activities listed at daily inspection.

#### B. Monthly maintenance

- Inspect the guide rollers (visual inspection of security devices, gaskets and bearings).
- Check that all mast bolts are tightened with the correct torque. Use a torque wrench.
- Check that all anchors are secure and re-secure any loose parts.
- Check the functioning of all limit switches.
- Grease the jacks and the king pins of the chassis.
- Grease the drive unit pressure rollers.
- Perform the activities listed at A.
- Perform all inspections as described in the appendix: Checklist mast climbing work platform type C.

#### C. Quarterly maintenance

- Check the motor brake (see section 9.3.2)
- Check the play in the guide rollers.
- Check the rack and pinion (visual).
- Perform the activities listed at B.

#### D. Annual maintenance

- Check the rack fixing bolts.
- Grease the universal joints on the drive mechanism for the differential gearbox.
- Grease the sliding tube on the drive mechanism for the differential gearbox.
- General inspection of paintwork, corrosion and welds.
- Check all welds of the mast climbing work platform.
- Check the oil level in the reduction box.
- Perform the activities listed at C.
- Perform all inspections as described in the appendix: Checklist mast climbing work platform type B.



#### E. Biennial maintenance

- Change the oil in the platform reduction gearbox.  
Lubricant specification for Stephan motors:  
ISO Viscosity class: ISO VG 220
  - Aral BMB
  - Shell Macoma W71
  - Esso Vartan 220
- Perform the activities listed at D.

#### F. Maintenance during storage of the machine

- Inspect the machine in its entirety.
- Check all vital parts and replace any which have become damaged.
- Clean and grease the rack and pinion drive.
- Inspect the mast elements (with the racks) and check that all separate connection pieces are in order.
- Check the lowest mast bolts for corrosion and replace them if necessary.
- Cover the basic machine with a tarpaulin; in every case, cover the control boxes and the limit switches.
- Screw out the jack of the chassis so that it does not rest on its wheels.
- For long-term storage, consult your dealer.

### 9.3 The motor brake

The motor has a built-in electromagnetic brake. This brake functions according to the "normally ON" principle, that is, when the motor has no power supply the brake is active and the motor shaft will be braked. ( $n = 0 \text{ rev./min}$ ).

The braking effect is achieved by friction between several discs and the brake must be used "dry" (not greased).

#### 9.3.1 Operation

The brake mechanism has a metal rotor (3) with friction material on both sides. Four pressure springs (7) in the stator exert an axial force on an anchor plate (4). This anchor plate is pressed by the spring force against rotor. The rotor is mounted on the motor shaft in such a way that it can slide in an axial direction along the shaft. Because the anchor plate presses against the rotor, the rotor is pressed against the friction plate (1). The contact between the friction material on either side of the rotor, the anchor plate and the friction plate results in the required braking effect.

The stator has a built-in braking coil (5) which produces a strong magnetic field when a DC current is applied to it.

When the brake is to be released, a current is made to flow through the braking coil. The resulting magnetic field "pulls" the anchor disc toward the stator,

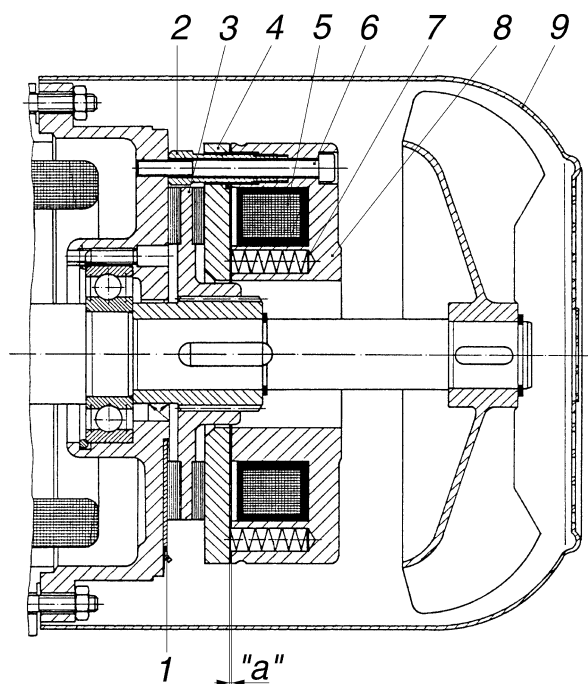

Fig.9-1 Motorbrake

thus releasing the brake.

It is also possible to release the brake manually. If the manual release lever is pressed in the direction indicated by the arrow on the cover, the anchor plate is moved against the spring pressure with the aid of two ball bolts, so that it is pressed towards the stator, releasing the brake.

### **9.3.2 Maintenance**

In normal use the motor brake is more or less maintenance free. However, after frequent raising and lowering of the platform it may be necessary to adjust the air gap between the anchor disk and the stator, and if necessary, to replace the rotor.

In order to check the condition of the brake, the width of the air gap "a" and the thickness of the friction material on the rotor must be measured every three months.

The air gap "a" is adjusted by the manufacturer to 0.3 mm / 0.012 in and must never be more than 1.1 mm / 0.043 in.

To check:

1. Switch off the mast climbing work platform at the mains switch and secure the switch with the padlock.
2. Remove the brake release lever using an open ended spanner.

3. Remove the fan cover (9) from the motor.
4. Use a feeler gauge to check the width of the air gap "a" adjacent to the hollow threaded collars (2).

The width of the air gap "a" must be adjusted as follows:

6. Remove the device securing the fan and remove the fan from the shaft.
7. Unscrew the hexagonal bolts (6) by a ½ turn.
8. Screw all the threaded collars (2) equally far into the stator (8).
9. Turn the hexagonal bolts (6) equally until the air gap "a" has the correct width.
10. Screw the threaded collars (2) out of the stator until they are in contact with the fixed part.
11. Check that the width of the air gap is the same over the whole of its length.
12. Tighten the hexagonal bolts (6) with a torque loading of 25 Nm / 18 lb ft.



The adjustment of the hand release may not be changed, not even when air gap "a" is readjusted, as security can be adversely affected.

13. Re-fit the fan and secure it to the shaft.
14. Mount the fan cover and the brake release mechanism.

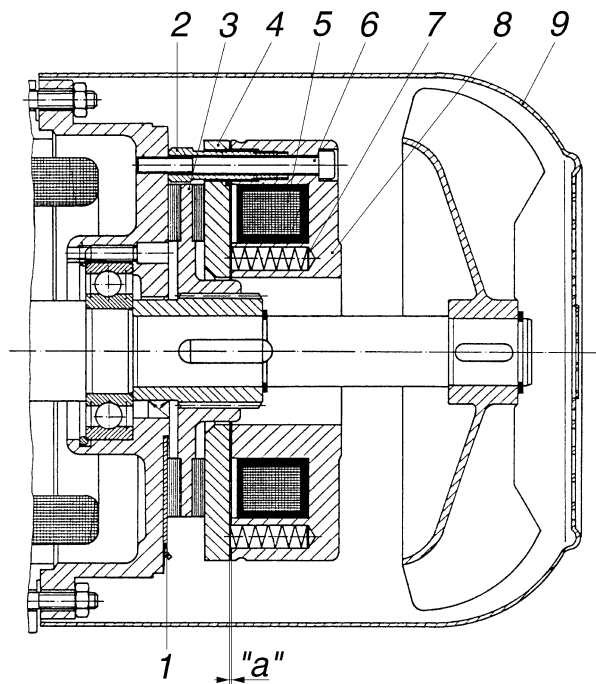

Fig.9-2 Motorbrake

## 10. MALFUNCTION ANALYSIS

The control box on the platform has an "information panel". This "information panel" consists of a display on which fault codes appear in the event of a malfunction. An explanatory list of fault codes is attached to the control box as an aid to rapid and efficient fault repair. The following table gives an indication of the methods to be employed in the event of a malfunction.

Code	Description	Malfunction	Solution
01	Motor M1 & M2 thermal overload	<ul style="list-style-type: none"> <li>- Platform loading too high</li> <li>- Voltage too low</li> <li>- Motor stalled</li> </ul>	<ul style="list-style-type: none"> <li>- Reduce loading</li> <li>- Consult an electrician</li> <li>- Consult an electrician</li> </ul>
02	Phaseguard relay	<ul style="list-style-type: none"> <li>- Main switch incorrect position</li> </ul>	<ul style="list-style-type: none"> <li>- Set main switch in the other position; if the malfunction is not corrected, consult an electrician.</li> </ul>
03	Emergency stop pushbutton	<ul style="list-style-type: none"> <li>- Pushbutton depressed</li> </ul>	<ul style="list-style-type: none"> <li>- Rotate pushbutton to release</li> </ul>
04	Limiting switch bottom	<ul style="list-style-type: none"> <li>- The machine has run too far downward</li> </ul>	<ul style="list-style-type: none"> <li>- Consult an electrician</li> </ul>
05			
06	Limiting switch top	<ul style="list-style-type: none"> <li>- The machine has run too far upwards</li> </ul>	<ul style="list-style-type: none"> <li>- Consult an electrician</li> </ul>
07	Others	<ul style="list-style-type: none"> <li>- Depending of erection, others</li> </ul>	<ul style="list-style-type: none"> <li>- Consult an engineer</li> </ul>
08	Gate/other	<ul style="list-style-type: none"> <li>- Gate is open</li> <li>- Connector not in socket</li> <li>- Switch defective or "sticking"</li> </ul>	<ul style="list-style-type: none"> <li>- Close the gate</li> <li>- Plug connector into socket</li> <li>- Check the switch</li> </ul>
12	Mast detection sensor	<ul style="list-style-type: none"> <li>- Machine run too far during assembly phase</li> <li>- Switch defective</li> </ul>	<ul style="list-style-type: none"> <li>- Move the machine downward; if the malfunction is not corrected, consult an electrician</li> </ul>
13	Control voltage	<ul style="list-style-type: none"> <li>- Fuse F104 deactivated</li> </ul>	<ul style="list-style-type: none"> <li>- Consult an electrician</li> </ul>

In all cases not covered by the above malfunction tables an electrician must be consulted.

Motor does not run	No power supply	<ul style="list-style-type: none"> <li>- Defective fuses in building site supply</li> <li>- Damaged cable</li> <li>- Motor safety relais switched off</li> <li>- Main switch defective</li> </ul>
	Voltage too low	<ul style="list-style-type: none"> <li>- Incorrect cable type</li> <li>- Cable is too long</li> </ul>
	42 Vac control voltage not present	<ul style="list-style-type: none"> <li>- Automatic fuses operated</li> </ul>
Voltage present but platform cannot be raised or lowered	Relays K102 en K103 are energized but platform does not move up or down	<ul style="list-style-type: none"> <li>- Motor brake locked</li> <li>- Adjust brake</li> </ul>
Other malfunctions	Brake distance too long	<ul style="list-style-type: none"> <li>- Adjust brake</li> </ul>
	The platform does not develop sufficient power	<ul style="list-style-type: none"> <li>- Inform your technical service or dealer</li> </ul>

In all cases not covered by the above malfunction tables an electrician must be consulted.

## 11. MACHINE DISPOSAL

### **General**

After a number of years of reliable service the life of every machine inevitably comes to an end. The machine must then be disposed of in an as environmentally friendly manner as possible.

Amongst others, the following possibilities present themselves:

- Part exchange for a new machine.
- Disposal by a recycling facility.
- Demolition.

### **Discarding the machine**

- Drain the oil out of the reduction gearbox and dispose of this via an authorized facility.
- Remove any usable parts.
- Dispose of the remainder via waste disposal facility.





## 12. LIST OF KEYWORDS

### A

Air gap	9-5
Anchor forces	1-7, 6-10
Anchor ramp	6-12
Anchoring	6-1, 6-10
Applications	1-1
Assembly	6-1

### B

Brake test	7-3
Buffer	5-3, 6-8

### C

Centrifugal brakes	2-1
Chassis	1-5
Component description	2-1
Contents	VI
Control box	5-2
Control components	5-1
Control light	5-2

### D

Dimensions	X
Disassembly	8-1
Down	5-2

### E

EC Declaration of Conformity	VIII
Electrical connections	2-2
Electrical installation	1-4
Emergency push-button	5-2
Emergency situation	7-4

### F

Fence posts	1-2
Fencing	6-4, 6-12
Foreword	V

### G

Gate safety switch	6-6
Ground pressure	6-3
Ground support	6-3

### H

Hom	5-3
-----	-----

### I

Illustrations	VII
Info panel	5-2, 10-1

### L

Lifting point	4-1
Lightning protection	6-13
Loading diagrams	1-6
Lower striker plate	6-5

### M

Machine disposal	11-1
Main switch	5-2
Maintenance	9-1
Malfunction analysis	10-1
Mast cover panels	6-9
Mast element	1-2
Maximum speed	4-2
Motor brake	9-4

### N

National requirements	6-2
Nylontron rollers	2-1

### O

Operation	7-1, 7-4
Original parts	9-1
Outriggers	6-13

### P

Personnel	3-3
Phase rotation	6-7
Platform	1-2
Platform construction	1-6
Platform elements	6-5
Platform width	6-12
Positioning	6-1, 6-4
Power supply	6-7
Power supply socket	5-1
Proximity switch	6-8

### R

Reaction force	7-1
Repositioning on the building site	4-2
Repositioning with a crane	4-3

### S

Safety	3-1
Safety after use	3-2
Safety features	3-2
Safety in use	3-1
Safety prior to use	3-1
Scaffold coupling	1-7
Steps	6-6
Storage	9-3
Symbols	IX



**T**

Technical details	1-1
Testing	7-3
Transport	4-1, 8-1

**U**

Up	5-2
----	-----

**W**

Weight	4-3
--------	-----

**A. CHECKLIST MAST CLIMBING WORK PLATFORMS TYPE B**

At least once a year, or sooner if circumstances require, for the benefit of the periodic inspection the installation should be checked against all the points on this list by an expert such as: a) your own technical department; b) the manufacturer/supplier; c) an independent authority.

**Mast climbing work platform description** .....

Manufacturer .....

Type .....

Factory or serial number(s) .....

Year of manufacture of the drives .....

Nominal load ..... kg

Platform length ..... m

Platform width ..... m

Maximum free-standing mast height ..... m

Erection set up mobile / stationary

Owner .....

Established in .....

Test date (day/month/year) .....

Following a successful inspection the day, month and year (in figures) are applied on the drive.

Date .....

Location .....

Inspected by (name person) .....

column 1: x = in order  
 column 2: x = not in order  
 column 3: x = not applicable

this list consists of **10** items  
 Mast climbing work platform B

		1	2	3
1	<b>General</b>			
	1.1 user manual			
	1.2 electrical circuit diagram			
2	<b>Operation</b>			
	2.1 unobstructed view of lift path			
3	<b>Mast</b>			
	3.1 construction			
	3.2 mounting to chassis/base frame			
	3.3 bolt connection, locking			
	3.4 top mast present			

column 1: x = in order  
 column 2: x = not in order  
 column 3: x = not applicable

	Mast climbing work platform B continued (1)	1	2	3
<b>4</b>	<b>Chassis</b>			
	4.1 outriggers, jacks			
	4.2 bolt and pin connection, locking			
	4.3 axles, wheels			
	4.4 tyres			
	4.5 steering gear			
	4.6 electrical operation and emergency stop chassis drive			
	4.7 brake operation			
<b>5</b>	<b>Drive unit</b>			
	5.1 bolt and pin connection, locking			
	5.2 fail safe brake or speed limiter			
	5.3 guide wheels			
	5.4 platform condition			
	5.4.1 railings			
	5.4.2 connection pieces and accompanying railings			
	5.4.3 floors			
	5.5 run-out safety			
	5.6 autolevel safety electric			
	5.7 autolevel safety mechanical			
	5.8 eccentric overload device			
	5.9 overload safety device			
	5.10 drive unit not out of mast guide			
	5.11 rack and pinion wear			
	5.12 guide wheels			
<b>6</b>	<b>Set up/erection</b>			
	6.1 stability			
	6.2 struts, ground support			
	6.3 free passage platform			
	6.4 free space erection site, fencing			
	6.5 space between platform and object			
	max. 0.3 m : kick board 0.15 high			
	0.3 - 0.5 m : kick board + railing at 0.7 m			
	greater than 0.5 m : kick board + knee rail + railing at 1.1m			

column 1: x = in order  
 column 2: x = not in order  
 column 3: x = not applicable

	Mast climbing work platform B continued (2)	1	2	3
<b>7</b>	<b>Electrical installation</b>			
	7.1 main switch blockable/lockable			
	7.2 electric cables, wiring			
	7.3 relay operation			
	7.4 thermal protection			
	7.5 phase protection (380V model)			
	7.6 safety earth			
	7.7 cable strain			
	7.8 hold to run buttons			
	7.9 emergency stops			
	7.10 eccentric overload protection			
	7.11 overload safety device			
	7.12 condition power supply cables			
	7.13 drive unit mounting			
	7.14 emergency limit switch			
	7.15 lower limit switches			
	7.16 upper limit switches			
	7.17 gate switch			
	7.18 transport switch			
	7.19 anchor ramp switch			
<b>8</b>	<b>Signs</b>			
	The presence of all signs in accordance with both the user manual and the applicable standards.			
<b>9</b>	<b>Various</b>			
	9.1 general state of maintenance			
	9.2 lubrication			
	9.3 panelling, mesh			
	9.4 paintwork (no rust formation)			
<b>10</b>	<b>Tests</b>			
	10.1 functional testing of safety components in accordance with manufacturers specifications.			

Note: An administrative record of the results of this checklist/inspection should be kept, it is recommended that the administration book be used for that purpose.



**B. CHECKLIST MAST CLIMBING WORK PLATFORMS TYPE C**

To be completed following the erection or relocation of the mast climbing work platform, preferably once per month for the benefit of erection set up inspections, special inspections and periodic inspections.

**Mast climbing work platform description**

Manufacturer .....

Type .....

Factory or serial number(s) .....

Year of manufacture of the drives .....

Nominal load ..... kg

Platform length ..... m

Platform width ..... m

Maximum free-standing mast height ..... m

Drive mobile / stationary

Erection set up .....

Owner .....

Established in .....

Test date (day/month/year) .....

Following a successful inspection the day, month and year (in figures) are applied on the drive.

Date .....

Location .....

Inspected by (name person) .....

column 1: x = in order  
 column 2: x = not in order  
 column 3: x = not applicable

this list consists of **26** items  
 Mast climbing work platform type C

		1	2	3
1	Is the stability of the mast climbing work platform guaranteed, on a hard and level surface ?			
2	Have the outriggers been deployed responsibly and in accordance with the user manual ?			
3	Has the ground support of the mast climbing work platform and jacks been implemented in accordance with specifications ?			
4	Has only slip-free material (preferably wood) been used for ground support the mast climbing work platform and jacks ?			
5	Following strut deployment are any wheels present free from the ground ?			
6	Have all anchors been fitted in accordance with the manufacturers regulations ?			

column 1: x = in order  
 column 2: x = not in order  
 column 3: x = not applicable

	Mast climbing work platform C continued (1)	1	2	3
7	Have all wall mounting anchors been fitted in accordance with the instructions of an expert ?			
8	Are all prescribed bolt connections present and tightened in the prescribed manner ?			
9	If a platform extension is present has it been fitted and fixed firmly in position in accordance with specifications ?			
10	Is the general state of the machine in order and free from mechanical deformities and shortcomings ?			
11	Have measures been taken to prevent users on the platform and non-users around –especially underneath- the platform from becoming trapped or crushed ? Has the machine not been erected in front of openings or in gangways where people continually pass by ? In case multiple mast climbing work platforms have been erected adjacently, is the minimum spacing between them at least 0.5 m in order to prevent the danger of crushing ?			
12	Have the railings been fitted and fixed firmly onto the platform: <ul style="list-style-type: none"> <li>• at a distance between wall and platform smaller than or equal to 0.3 m: at least one kick board 0.15 high.</li> <li>• distance smaller than or equal to 0.5: kick board + railing at 0.7 m</li> <li>• distance greater than 0.5 m: kick board + railing at 1.1m + knee rail.</li> </ul>			
13	Are all other railings present and fixed firmly in position ?			
14	Is the mast guard with a minimum height of 2 m present and fixed in position ?			
15	Is the mast climbing work platform fitted with a run-out safety at the end of the mast ?			
16	Is the mast climbing work platform eccentric overload protection functional (see user manual) ?			
17	Does each motor brake function independently when in a stationary condition (at least 2 independent brakes present, see user manual) ?			
18	Is the mechanical platform autolevel safety functional ? (only applicable with 2 masts)			
19	Is the emergency lowering system functional (see user manual) ?			



column 1: x = in order  
 column 2: x = not in order  
 column 3: x = not applicable

	Mast climbing work platform C continued (2)	1	2	3
20	Are the following functional:			
	a Emergency switch			
	b Lower limit switch			
	c Lower emergency limit switch			
	d Upper limit switch			
	e Upper emergency limit switch			
	f Gate switch			
	g Electrical autolevel system (if applicable)			
	h Anchor ramp switch (if applicable)			
	i Transport locking switch			
	j Phase guard relay			
21	Does the power supply cable run completely free ?			
22	Are there no damaged power supply cables, connector plugs or other electrical components ?			
23	Is the main switch blockable/lockable ?			
24	Is the user manual at least available in the national language ?			
25	Are the type plates, correct load signs, the warning signs and operating instructions: UP, DOWN, and EMERGENCY STOP present ?			
26	Are the operating buttons located in such a manner that the operator has a clear view over the entire platform ?			

Seen by the foreman / supervising person

Note: An administrative record of the results of this checklist/inspection should be kept, it is recommended that the administration book be used for that purpose.

