

# HEK GTP 1500

## Transport Platform



### POWER SUPPLY REQUIREMENTS

Voltage: 240V, 3 Phase  
 Frequency: 60 Hz  
 Breaker Size: 50A

### MACHINE SPECIFICATIONS

Platform Speed: 39 ft/min  
 Maximum Height:  
     Anchored: 394 ft  
     Freestanding: 0 ft  
 Anchor Distance: 20 ft - 26 ft  
 Height of First Anchor: 10 ft - 13 ft  
 Mast Height Above Top Anchor: 10 ft  
 Standard Extension: N/A  
 Motors (Vertical Travel): 2 x 4.8 kW  
 Motors (Horizontal Travel): N/A  
 Control Voltage: 42V  
 Starting Current: 190A  
 Running Current: 40A

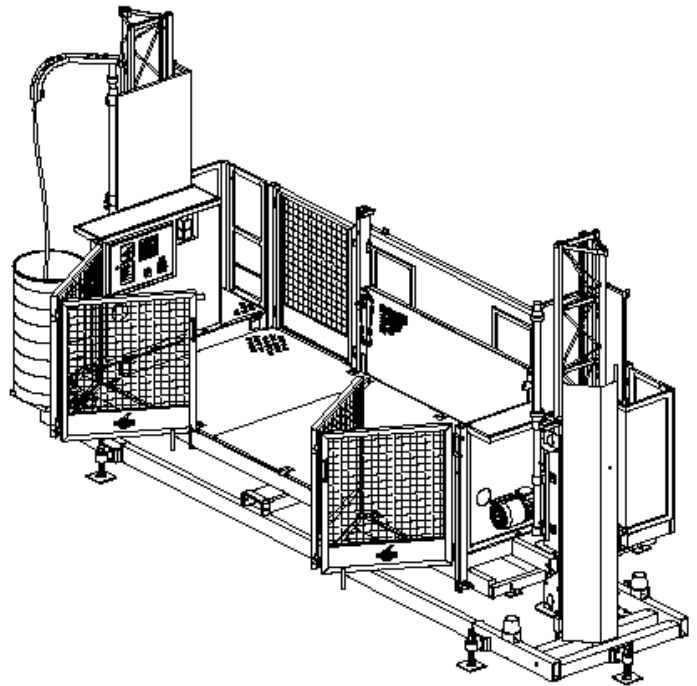

### COMPONENT WEIGHTS

Base Machine:<sup>1</sup> 4619 lb  
 Mast (4'-11"): 110 lb

<sup>1</sup> Weight of base machine includes 2 masts and 2 red top masts.

### LIFTING CAPACITY

3300 Pounds

### DIMENSIONS

A	13'-1"
B	4'-11"
C	5'-10"
D	20'-6"

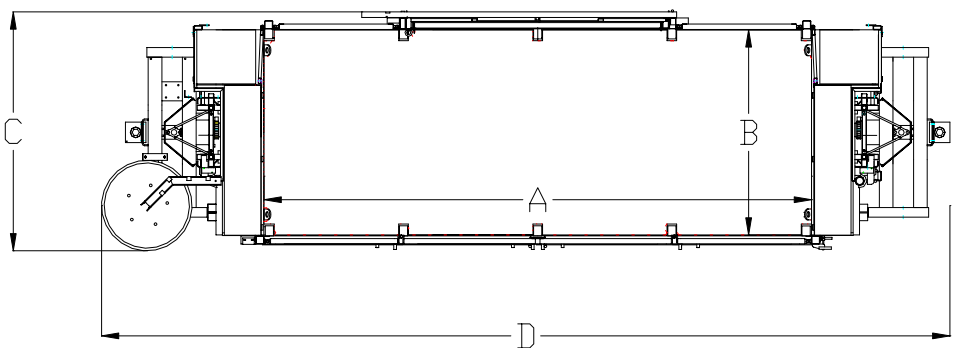

Alimak Hek, Inc. Construction Division

3745 Cherokee Street Suite 605 • Kennesaw, GA 30144  
 Tel (800) 343-2449 • (770) 424-3232 Fax (770) 424-4647  
 www.alimakhek.com

1100 Boston Avenue • Bridgeport, CT 06601  
 Tel (800) 525-4625 • (203) 367-7400 Fax (203) 367-9251  
 www.alimakhek.com