



OPERATING AND
MAINTENANCE
HANDBOOK

JOLLY JUNIOR CE



SINGLE/TWIN MAST PLATFORM

CONFORMITY CE DECLARATION

The Pro-tempore Administrator of the society SAFI S.r.l. with seat in: Via S. Rocco, snc
31041 CORNUDA (TV)

DECLARES

That the single - twin mast working platform mod.: JOLLY JUNIOR CE

- Serial Nbr. :
- Year of construction:

made by:

- Two motor groups:
 - Serial number :
 - Serial number:
- (Note: Before the use of the machine please check the instruction manual)*

produced by **SAFI S.r.l.**;

has been developed, designed and produced in conformity with the following Directions and Rules:

- **DIRECTION 98/37/CE**: Machine Direction;
- **D.Lgs. 626/94**: Safety and health of the workers during the work;
- **DIRECTION 73/23/CEE** – "Low tension";
- **DIRECTION 89/336/CEE** – "Electro-magnetic compatibility";
- **RULE UNI EN1495** – " Mast climbing work platforms on mast towers";
- **RULE EN 292 - Part 1 and 2**: Safety of the machine – Fundamental concepts, general principles of design;
- **RULE EN 60204-1:1992**: Safety of the machine – Electrical equipment of the machines;

The documentation is complete and available.

The operating and service manual for the use and maintenance of the machine is integrant part of the present declaration.

The platform is in conformity with the type certificate:

O.C.E. Organismo di Certificazione Europea S.r.l. (Notificato CEE n. 0397)
Via Ancona 21 – 00198 ROMA - ITALY

EC-TYPE TEST CERTIFICATE NBR. 48/D DATED 27.02.2001

In case of modifications of the machine from third parties the conformity with the sample submitted to checking cannot be guaranteed and therefore the present declaration loses any validity.

Cornuda, 13 JUNE 2005

SAFI S.r.l.



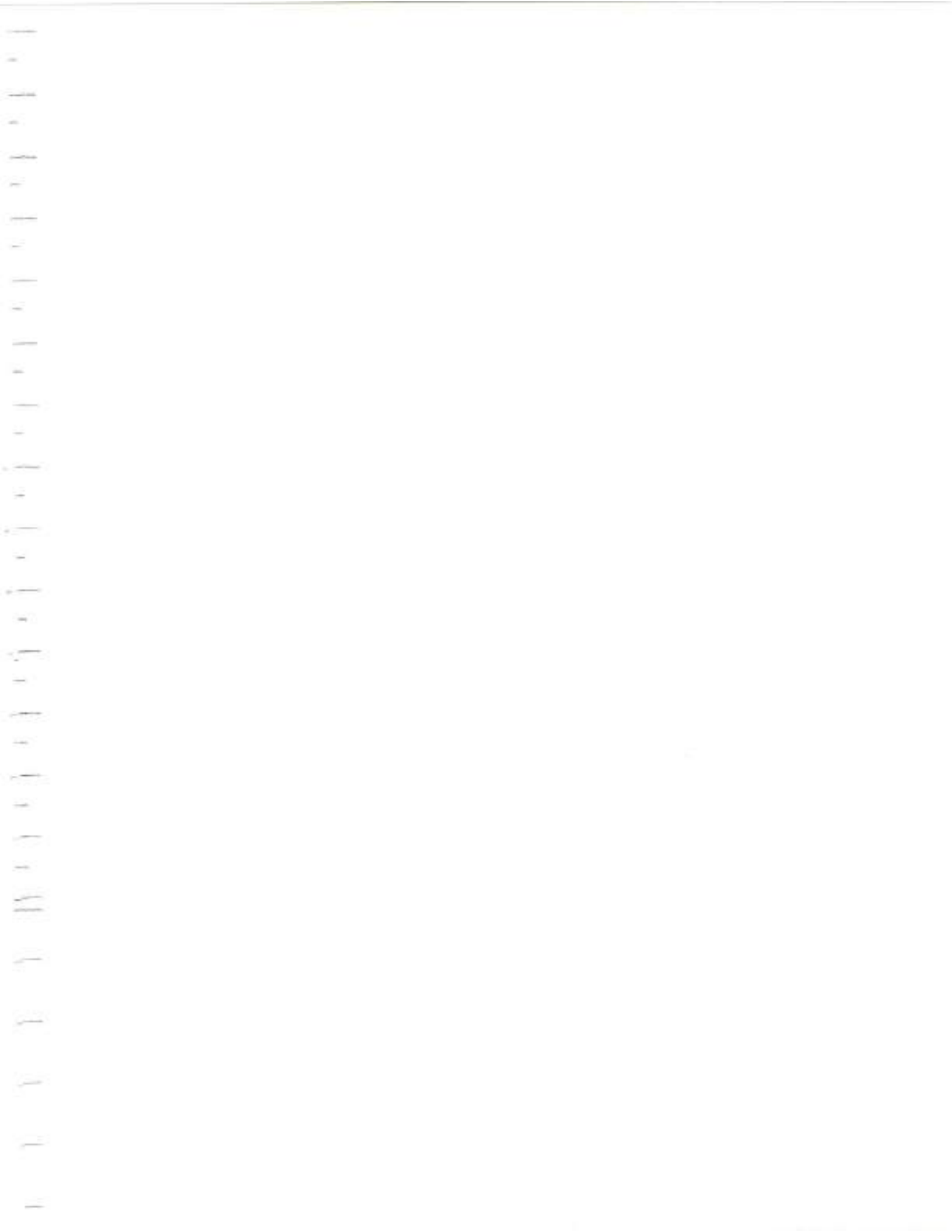



MACHINE DATA

DATE	13/06/2005
CUSTOMER	AMERICAN PLATFORM AND SCAFFOLDING
ADDRESS	823 FAIRVIEW AVENUE 21080 LINTHICUM - MARYLAND U.S.A.
TYPE OF MACHINE	SINGLE MAST CLIMBING WORK PLATFORM
MODEL	MOD. JOLLY JUNIOR
SERIAL NO	12/018/05
YEAR OF MANUFACTURE	2005
CE MARK REFERENCE	OCE N. 47D DATED 27.02.01
COUNTRY OF PRODUCTION	ITALY
MOTOR UNIT SERIAL NUMBER	104/011/05 104/012/05
PARACHUTE BRAKE NBR.	01/012/05 01/013/05



Notificato CEE N° 0397

Organismo di Certificazione Europea S.r.l.

ATTESTATO DI ESAME CE DI TIPO

ATTESTATION CE DE TYPE
EC-TYPE TEST CERTIFICATE
EG-BAUMUSTERBESCHEINIGUNG

N° 48/D

SAFI S.r.l.

Via S. Rocco, 8 – Cornuda (TV)

Costruttore / Fabricant / Manufacturer / Hersteller

**Piattaforma di lavoro autosollevante bicolonna
mod. JOLLY JUNIOR CE
con estensione della piattaforma a 17,759 m**

Prodotto, Tipo / Produit, Type / Product, Type / Produkt, Typ

N° 47/D – 27 febbraio 2001

Numero e Data del Rapporto di Prova / Date et Numéro du Rapport d'Essai
Date and Number of Test Report / Datum und Nummer des Prüfberichtes

89/392/CEE

Direttiva(E) della Comunità Europea / Directive(S) de la Communauté Européene
EC-Directive(S) / EG-Richtlinie(N)

Altre condizioni e limitazioni sono contenute nelle pagine allegate
Autres conditions et limitations sont contenues dans les pages annexes.
Other conditions and limitations have been presented on following pages.
Andere konditionen und beschränkungen in die anlagen seiten enthalten sind.

27 febbraio 2001

Ing.  Lombardi



Ing.  Cilia

OCE Organismo di Certificazione Europea S.r.l.



Preliminary prescriptions

During the first 100 working hours do not lubricate neither the pignons nor the racks. During this first period of working there is a certain deposit of zinc and other impurities among the pignon's teeth which must be removed using an adequate in size drift. If this operation is not effected EVERY DAY, some serious and dangerous malfunctions could occur to the machine.

In the event that during the use, rising or descending, some abnormal noises were heard block immediately the machine and ask for the intervention of a qualified technician.

The manufacturer declines any responsibility for inconveniences arising from the non-observance of the above mentioned rules and prescriptions contained in this manual.

CONTENTS

- 1.0 Guide for reference
 - 1.1 Scope and limits of the instruction booklet
 - 1.2 Where and how to keep the instruction booklet
 - 1.3 Amendments to and integration of the instruction booklet
 - 1.4 Exceptions to liability
- 2.0 Technical characteristics
- 3.0 Description
 - 3.1 JOLLY JUNIOR CE Twin-mast platform
 - 3.2 JOLLY JUNIOR CE Single-mast platform
- 4.0 Components
 - 4.1 Base
 - 4.2 Vertical elements
 - 4.3 Beam
 - 4.4 Gates and guard-rails
 - 4.5 Deck and access stairway
 - 4.6 Gear-motor unit
 - 4.7 Electrical system
 - 4.8 Switchboard
- 5.0 Erection and dismantling
 - 5.1 General information
 - 5.2 Safety norms
 - 5.3 Assembly of base and positioning of stabilisers
 - 5.4 Assembly of platform
 - 5.5 Electrical connections
 - 5.6 Erection of the masts
 - 5.7 Protective screening
 - 5.8 Dismantling
- 6.0 Use
 - 6.1 General information
 - 6.2 Centrifugal parachute brake
 - 6.3 Emergency manual descent
- 7.0 Platform arrangements and payload tables
 - 7.1 Twin mast
 - 7.2 Single mast
- 8.0 Maintenance
 - 8.1 Information regarding safety
 - 8.2 Preliminary and periodic controls
 - 8.3 Maintenance of the self-braking unit
 - 8.4 Speed reducer
- 9.0 Markings
- 10.0 Control register
 - 10.1 Register cards
 - 10.2 Periodic checks

INDEX OF FIGURES

- Figure 3.1.1 17.76 metres (58.26 feet) twin-mast platform
- Figure 3.2.1 5.3 metres (17.38 feet) single-mast platform
- Figure 4.1.1 Base
- Figure 4.2.1 Vertical elements
- Figure 4.3.1 1433 mm (4.70 feet) long beam
- Figure 4.3.2 795 mm (2.61 feet) short beam
- Figure 4.4.1 Gate and gate guide
- Figure 4.4.2 Gate with guide
- Figure 4.4.3 Guard-rail
- Figure 4.4.4 Right end guard-rail
- Figure 4.4.5 Left end guard-rail
- Figure 4.5.1 Wooden decks
- Figure 4.5.2 Access stairway
- Figure 4.6.1 Gear-motor unit
- Figure 4.7.1 JOLLY JUNIOR CE twin-mast platform auxiliary circuit
- Figure 4.7.2 JOLLY JUNIOR CE twin-mast platform power circuit
- Figure 4.7.3 JOLLY JUNIOR CE single-mast platform auxiliary circuit
- Figure 4.7.4 JOLLY JUNIOR CE single-mast platform power circuit
- Figure 4.8.1 External and internal view of the switchboard
- Figure 5.2.1 Safety area
- Figure 5.3.1 Maximum stabiliser reactions
- Figure 5.3.2 Positioning of platform stabilisers
- Figure 5.3.3 Base - maximum dimensions
- Figure 5.3.4 Twin-mast platform - front view
- Figure 5.3.5 Assembly of lifting unit
- Figure 5.4.1 Twin-mast platform – e.g. 16.012 metres (52.53 feet) arrangement
- Figure 5.4.2 Twin-mast platform - erection stage 1
- Figure 5.4.3 Twin-mast platform - erection stage 2
- Figure 5.4.4 Twin-mast platform - erection stage 3
- Figure 5.4.5 Twin-mast platform - erection stage 4
- Figure 5.4.6 Twin-mast platform - erection stage 5
- Figure 5.4.7 Twin-mast platform - erection stage 6
- Figure 5.4.8 Twin-mast platform - erection stage 7
- Figure 5.4.9 Overhang/cantilever towards the wall
- Figure 5.4.10 Levelling operation
- Figure 5.4.11 Levelling operation – e.g. of inclined surface
- Figure 5.4.12 Detail of levelling system
- Figure 5.4.13 View of levelling system
- Figure 5.4.14 Detail of operation
- Figure 5.4.15 Single-mast platform - 5.3 m (17.38 feet) arrangement
- Figure 5.4.16 Single-mast platform - erection stage 3
- Figure 5.4.17 Single-mast platform - erection stage 4
- Figure 5.4.18 Single-mast platform - example of erection
- Figure 5.5.1 Control panel shield
- Figure 5.6.1 Anchorage
- Figure 5.7.1 Protective screening (assembly drawing)
- Figure 5.7.2 Details of position of brackets, clamps and struts
- Figure 6.2.1 Centrifugal parachute brake
- Figure 6.3.1 Resetting of the parachute brake

- Figure 7.1.1 load chart (TAB. 1/3)
- Figure 7.1.2 load chart (TAB. 2/3)
- Figure 7.2.1 load chart (TAB. 3/3)
- Figure 8.3.1 Electric motor self-braking unit
- Figure 8.4.1 Speed reducer
- Figure 9.0.1 Serial number plate, stabiliser reaction plates and large central screw plates
- Figure 9.0.2 Positioning of reaction plate
- Figure 9.0.3 Position of payload table
- Figure 9.0.4 Machine performance table

INDEX OF TABLES

Table 1:	PERFORMANCE
Table 2:	SAFETY DEVICES
Table 3:	TECHNICAL CHARACTERISTICS
Table 4:	WEIGHT OF COMPONENTS
Table 5:	COMPONENTS OF THE GEARMOTOR UNIT
Table 6:	WIRING DIAGRAM SYMBOLS
Table 7:	ELECTRIC CONTROL PANEL
Table 8:	HEIGHTS IN RELATION TO LENGTH
Table 9:	ELECTRICAL SYSTEM TROUBLESHOOTING
Table 10:	CONNECTING ELEMENTS
Table 11:	MAXIMUM REACTIONS
Table 12:	TIGHTERING TORQUE
Table 13:	BEAUFORT SCALE
Table 14:	PARTS AND RELATIVE LUBRICANTS
Table 15:	SELF-BRAKING UNIT COMPONENTS
Table 16:	LUBRICATION

CHAPTER 1

Guide for reference

1.1) Scope and limits of the instruction booklet.

This booklet accompanies the machine that has been sold and contains instructions for its transportation, erection, use and maintenance, in accordance with instructions contained in the machines directive EEC 89/392. All the operations which fall within normal use and routine maintenance of the machine have been taken into consideration when preparing this booklet.

The instructions should therefore be scrupulously followed for correct, optimum use.

The operating and maintenance booklet is an integral part of the machine and instructions provided by European norms on the methods of preparing the operating booklet have been followed, in particular:

EN 292/2 - Ch.5

Pr En 1495 January 1997

The user must read the booklet carefully, referring in particular to all norms and instructions regarding safety, before carrying out any installation operation or using the machine.

1.2) Where and how to keep the instruction booklet

This booklet can in no way substitute adequate experience, which personnel assigned to using the machine should have already obtained on similar machines or may gain on this machine under the guidance of trained personnel.

The machine should only be used by authorised, trained personnel. All operations requiring work on machine components should be done by authorised, trained technical personnel.

This booklet (or complete copy) should always be on board the machine for immediate consultation by the operator and should be kept in good condition.

1.3) Amendments to and integration of the instruction booklet

Due to the manufacturer's policy of constant, continual product improvement, the supplied machine could differ in some technical details compared to what is described in this booklet; any variations will in any case always be accompanied by specifications which will illustrate their function and characteristics; should there be differences with regard to the basic contents of the booklet, the user should immediately request supplementary data sheets. Safi reserves the right to update its production and relative instruction booklets following development in techniques, the acquisition of new experience or a change in provisions laid down by the law, without being obliged to alter machines that have already been sold or their relative booklets.

1.4) Exceptions to liability

Safi cannot be held liable for any damage or injury due to incorrect use of the equipment or failure to comply with the instructions given in this booklet. Safi cannot be held liable for troubles, damage or injury due to:

- improper use of the machine;
- use by untrained personnel;
- use that is contrary to the safety norms provided for by specific community or national laws;
- total or partial failure to comply with instructions contained in this booklet;
- failure to comply with instructions for the maintenance recommended in this booklet;
- alterations or repairs not authorised by the manufacturer;
- use of other than original spare parts, which are indicated in the spare parts catalogue.

For SERVICE contact:

SAFI, Via S.Rocco, 8 31041 Cornuda - TV - Italy
E-mail: Box@SAFI.it

CHAPTER 2

Technical characteristics

Table 1: Performance

TYPE OF PLATFORM	JOLLY JUNIOR CE TWIN MAST	JOLLY JUNIOR CE SINGLE MAST
Maximum height	100 m	100 m
Total maximum capacity load	800 daN	400 daN
No. persons allowed	4	2
Maximum work deck length	17.759 m	5.297 m
Work deck width	0,8 m	0,8 m
Overhang towards wall	0,6 m	0,6 m
Speed	6 m/min	6 m/min
Maximum permissible wind speed during operation with anchors	55,8 km/h	55,8 km/h
Maximum thrust on guard-rails	90 daN	60 daN
Maximum wind speed during erection/dismantling.	45,7 km/h	45,7 km/h
Maximum wind speed when out of commission	151,2 km/h	151,2 km/h
Power supply	254...277/440...480 V – 60 Hz	254...277/440...480 V – 60 Hz
Single-phase	190....240 V – 60 Hz	190....240 V – 60 Hz
Weight at base	2060,1 daN	8394 daN

Table 2: Safety devices

Reduction gears
Self-braking electric motors
Switchboard with low-voltage controls (24 V)
Ascent-descent-level limit switches
Mast emergency limit switch
"Gate" limit switch
"Descent" runby limit switch
"Level" runby limit switch
Trestlework protective screening
Possibility of emergency manual descent

Table 3: Technical characteristics

40 mm thick deal floors
Minimum height of work deck from the ground 1.5 m (4.92 feet)
Wall anchorage every: 6 m (19.68 feet)
External guard-rails with plate toeboard height 200 mm (0.65 feet)
Wall-side guard-rails when the horizontal bridge is over 300 mm (0.98 feet) from the wall
Noise level Leq: 60 dB(A)

Table 4: Weight of components

DESCRIPTION	WEIGHT daN
Base complete with stabilisers	146
Arm complete with stabilisers	12.5
Complete motor unit	227
Self-braking electric gear-motor	55
Centrifugal parachute brake	36
Vertical element	36.5
End vertical element	30.5
1433 mm (4.7 feet) beam with wall-side brackets	44
Wall-side brackets	2
Complete long connecting pin	0.5
Complete short connecting pin	0.4
1433 mm (4.7 feet) beam with brackets, floor or deck, guard-rail, 3 single columns and 3 short connecting pins	94.7
Wooden platform floor	20
1400 mm (4.59 feet) guard-rail	17.5
R.h. end guard-rail	13.5
L.h. end guard-rail	13.5
Single column	4
Double column	4.5
Protective column grating	13.5
Gate with guide	29
Access stairway	16
Switchboard with shield	41
Anchoring bracket	3.5
Anchorage clamp	7.5
Right-angle clamp	1.5

WEIGHT OF FRAMEWORK

Length: _____ feet.

Height: _____ feet.

Weight at bottom of framework L=..... feet:lbs

Weight at bottom of platform L=..... feet:lbs

weights

DESCRIPTION	No.	WEIGHT lbs (component)	TOTAL WEIGHT
Vertical elements		36.5	
End vertical elements		30.5	
Anchoring bracket		3.5	
Anchorage clamp		7.5	
Right-angle clamps		1.5	
Electrical cable (weight per metre)		0.793	
TOTAL ADDED WEIGHT (lbs)			

TOTAL WEIGHT OF FRAMEWORK = _____ lbs
(Weight at base + Added weight)

CHAPTER 3

Description

The JOLLY JUNIOR CE model platform is a dynamic machine which uses the gearmotor-driven pinion-rack to move a work deck up to different heights.

The platform offers the user countless advantages such as: a considerable reduction in cost per square metre of facade that is covered thanks to the shorter time required for erection and dismantling compared to traditional systems; a certain independence for the operators using it since they can carry with them all they need without requiring other hoisting means; physical fatigue is consequently reduced and it is easier to carry out work because the platform may be positioned and stopped at whatever height is desired; greater safety, since all the necessary protective devices have been used to keep persons and property from harm.

In addition it enhances the image, from a site technical/organisational point of view, of the building contractors using it.

3.1) JOLLY JUNIOR CE twin-mast platform

The JOLLY JUNIOR CE model twin-mast platform consists of two bases on which vertical elements are mounted, fitted with rack and a horizontal mobile work deck activated by one or two lifting units.

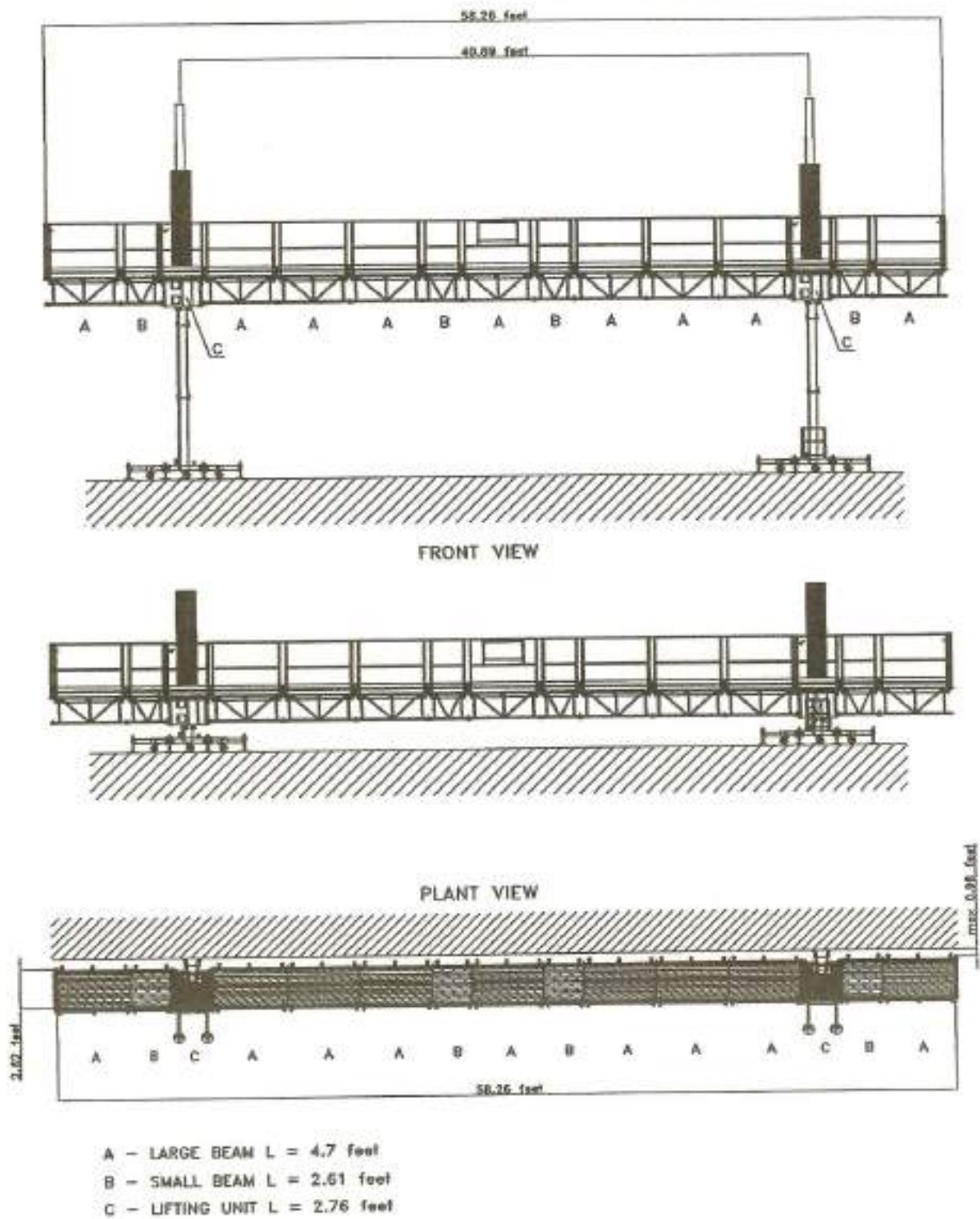

FIG. 3.1.1 17.76 meters (58.26 feet) twin-mast platform

3.2) JOLLY JUNIOR CE single-mast platform

The SAFI JOLLY JUNIOR CE model single-mast platform consists of a base with 5 stabilisers. Vertical elements fitted with rack and a horizontal mobile work deck activated by two lifting units are mounted onto this base. The machine may be made with the components of the two-mast model. Base, vertical elements, gear-motor units, beams, guard-rails are the same as those for the JOLLY JUNIOR CE twin-mast platform.

The switchboard of the twin-mast platform may in turn be transformed into switchboard for the single-mast platform. Since the single-mast platform has just one gear-motor unit, just one multiple socket is used, whilst the other socket is isolated by means of a jumper that it is provided.

That is why the description of the erection, dismantling and operating procedures for the twin-mast platform are also applicable to the single-mast platform, except for those components not designed for the single-mast version.

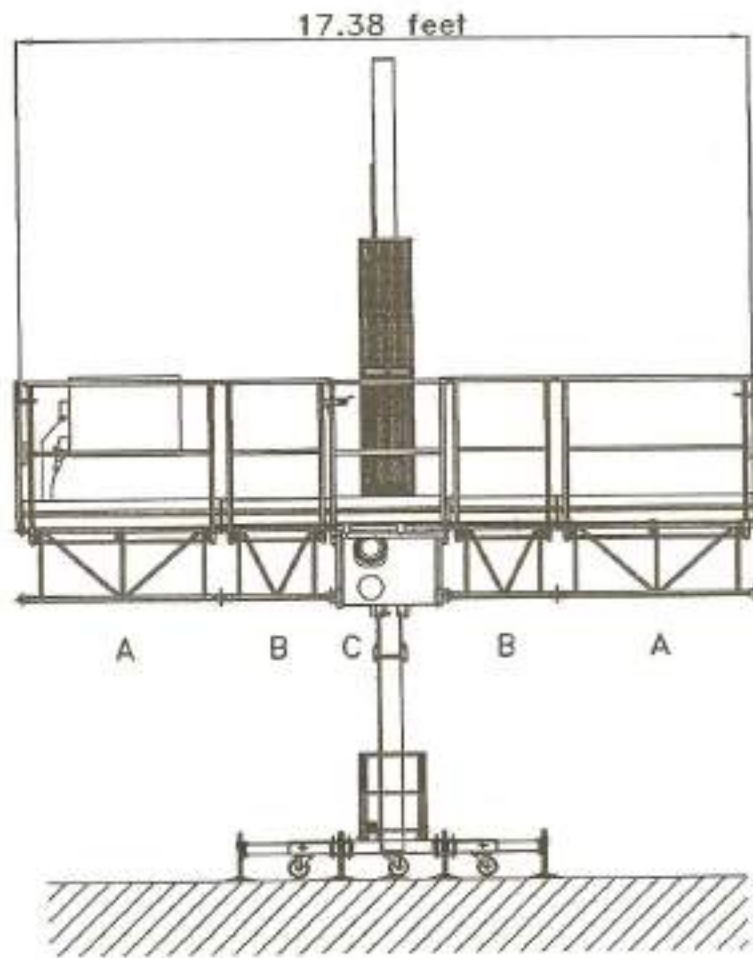

FRONT VIEW

- A - 4.70 FEET BEAM
- B - 2.61 FEET BEAM
- C - 2.76 FEET LIFTING UNIT

FIG. 3.2.1 5.3 meters (17.38 feet) single-mast platform

CHAPTER 4

Components

4.1) Base

Each of the two bases consists of a steel section frame and serves as a distributing element, through 5 points of support, to earth of the load which is transmitted from the vertical mast. The points of support consist of 4 screw or jack stabilisers, which guarantee the verticality and stability of the mast. The large central screw supports the mast load.

The base is fitted with four swivelling wheels mounted on special supports to allow the platform to be moved on site without having to completely dismantle it.

It is also fitted with a rubber shock absorber to counteract any impact of the hoisting system. For dimensions, see the drawing below.

N°	DESCRIPTION
1	RUBBER SHOCK ABSORBER
2	LARGE CENTRAL SCREW
3	SWIVELLING WHEEL
4	STABILISER
5	STABILISER ARM
6	LARGE SCREW RING NUT

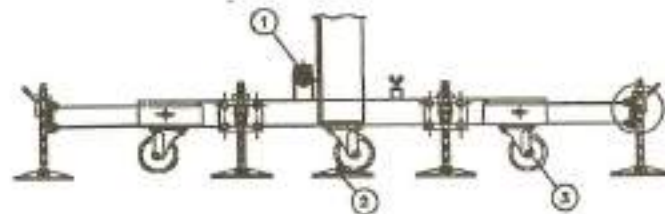
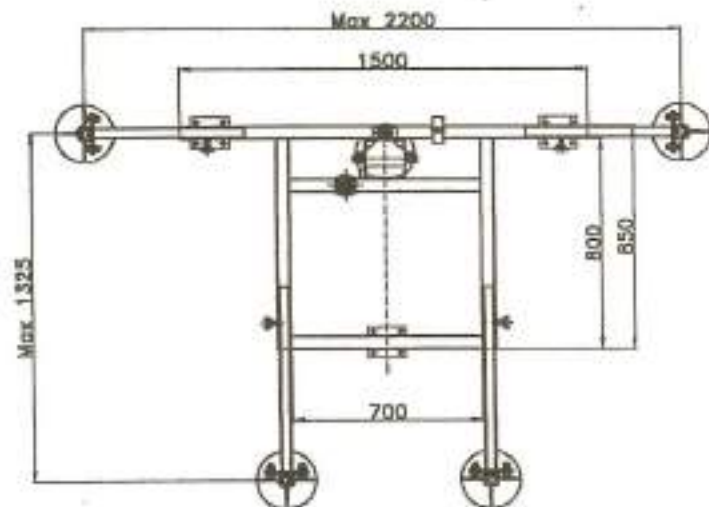

WEIGHT AT THE BASE = 146daN

FIG. 4.1.1 Base

4.2) Vertical elements

These consist of 1.492 m (4.89 feet) high tubular modular elements, connected one on top of the other by means of galvanised steel screw stays + nut + one plain washer

The overall dimensions are: height 1.492 m (4.89 feet), base 150 x 150mm (0.49 feet x 0.49 feet).

N°	DESCRIPTION
1	SCREW STAY
2	HEXAGON NUT
3	WASHER

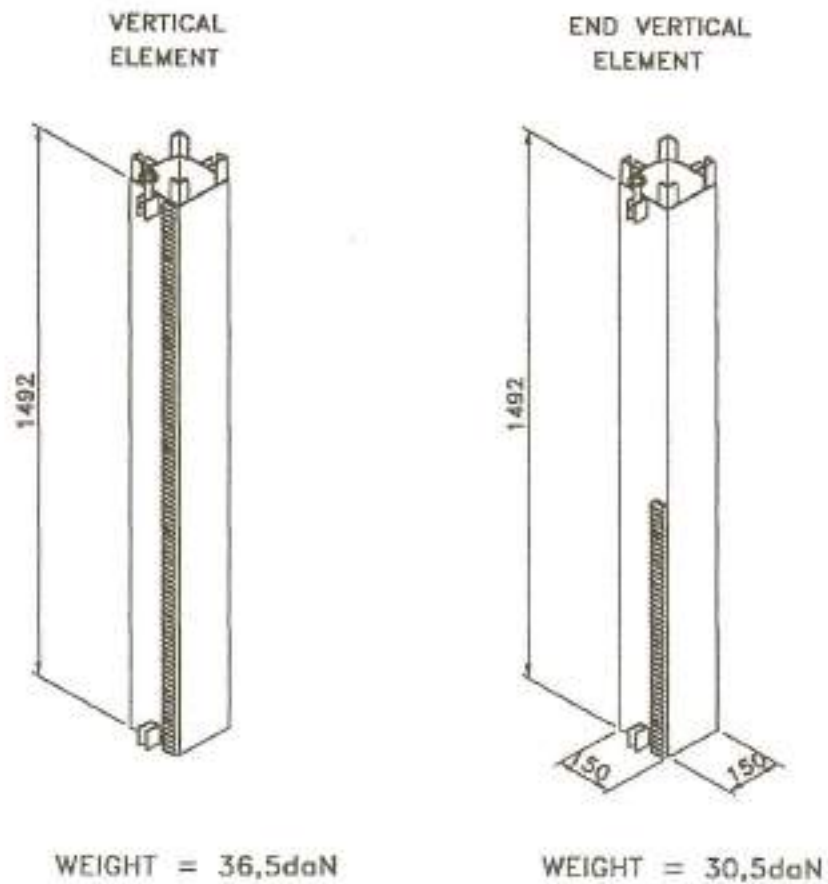
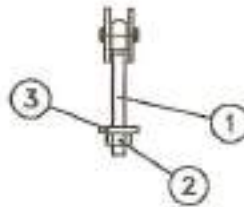
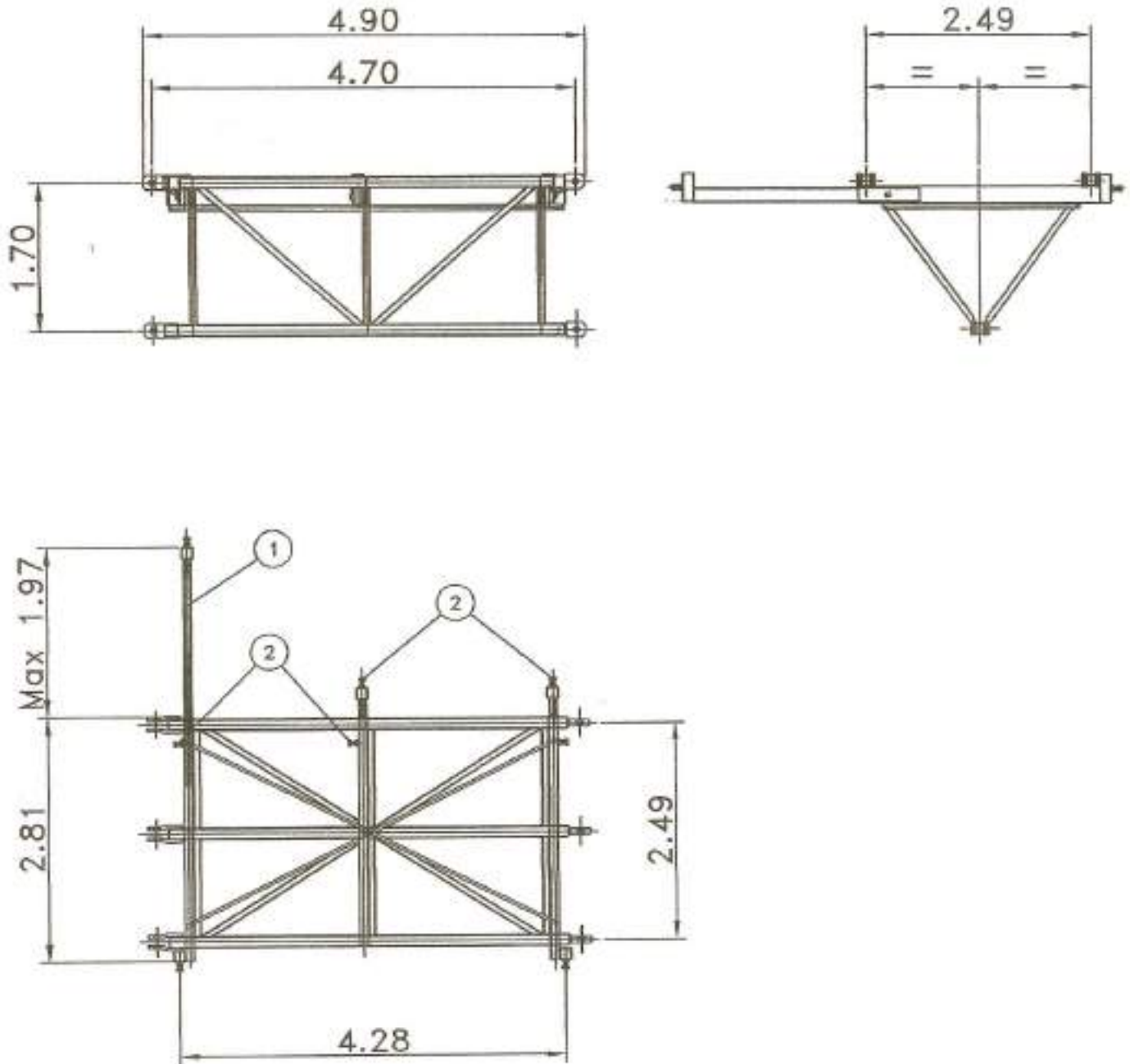

FIG. 4.2.1 Vertical elements

4.3) Beam

N°	DESCRIPTION
1	EXTENSIONS
2	EXTENSIONSLOCK WING NUT



COMPLETE BEAM WEIGHT = 97.0 lbs

FIG. 4.3.1 - 1433 mm (4.70 feet) long beam

N°	DESCRIPTION
1	EXTENSIONS
2	EXTENSIONSLOCK WING NUT

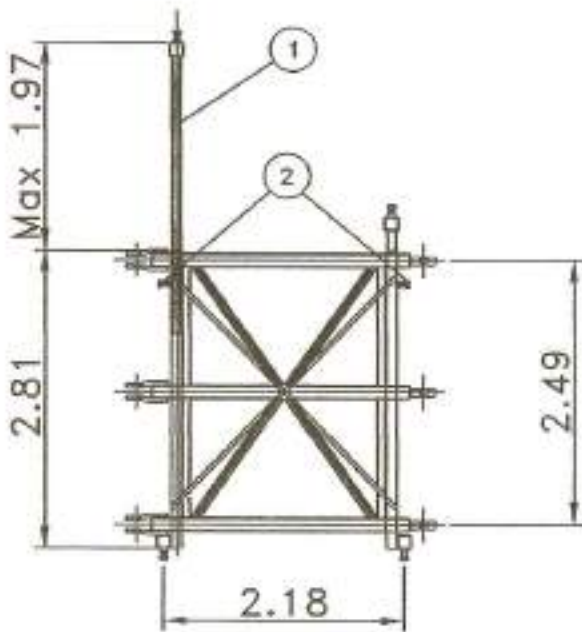
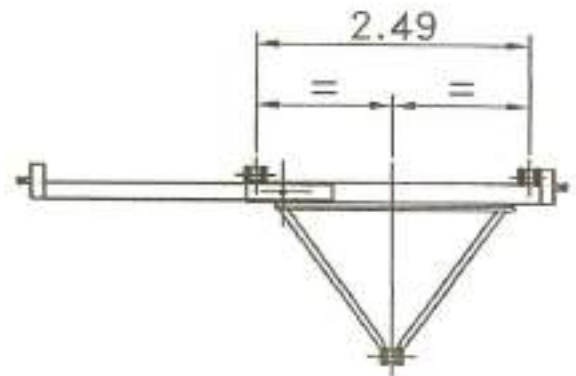
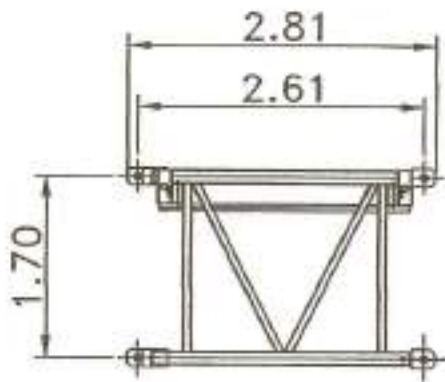

COMPLETE BEAM WEIGHT = 57.3 lbs

FIG. 4.3.2 – 795 mm (2.61 feet) short beam

4.4) Gates and guard-rails

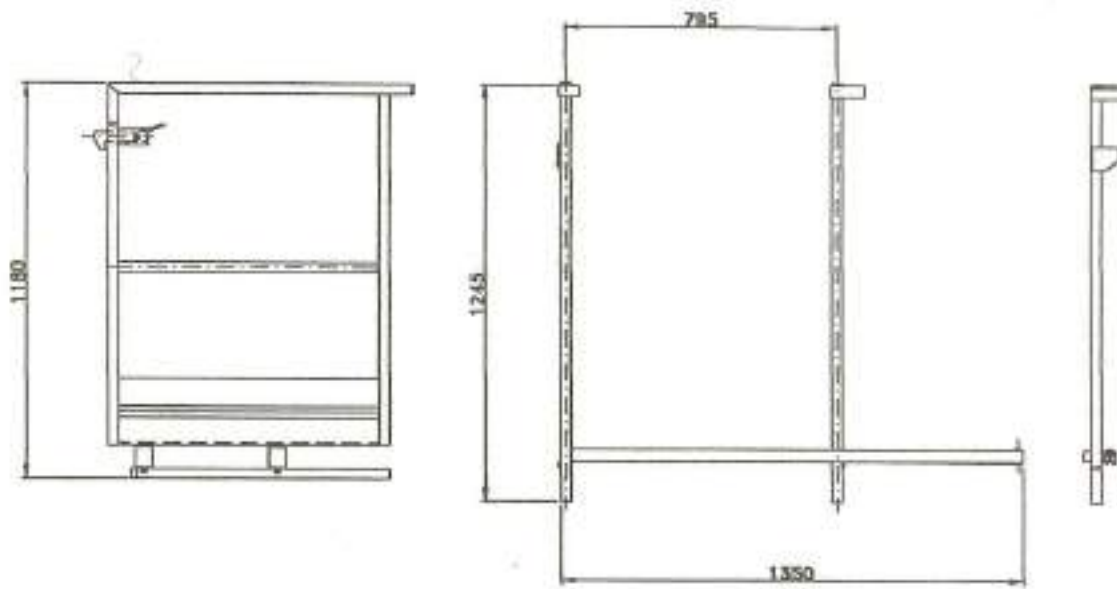

FIG. 4.4.1 Gate and gate guide

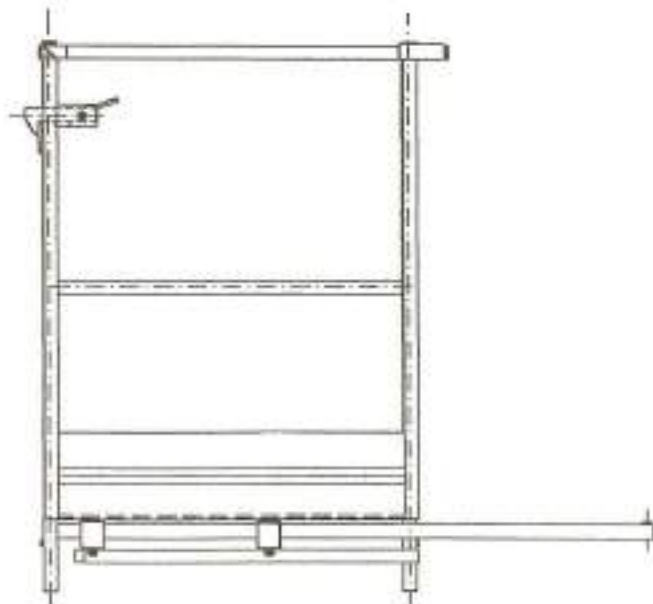

FIG. 4.4.2 Gate with guide

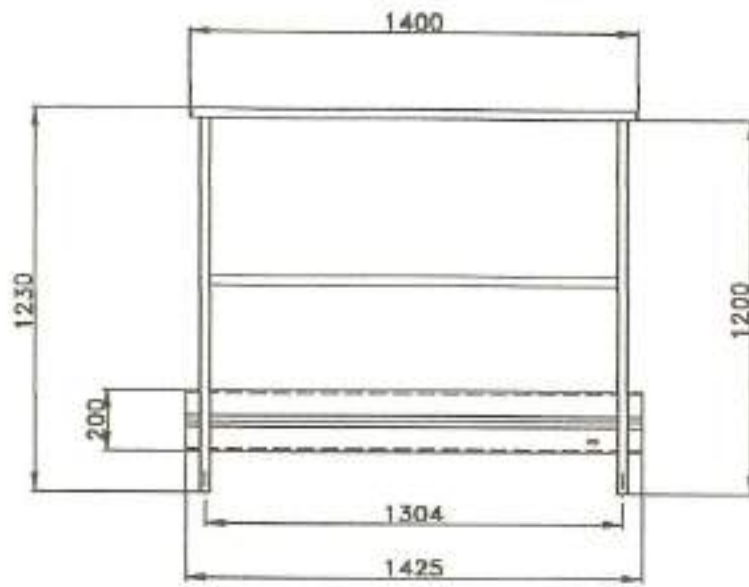

FIG. 4.4.3 Guard-rail

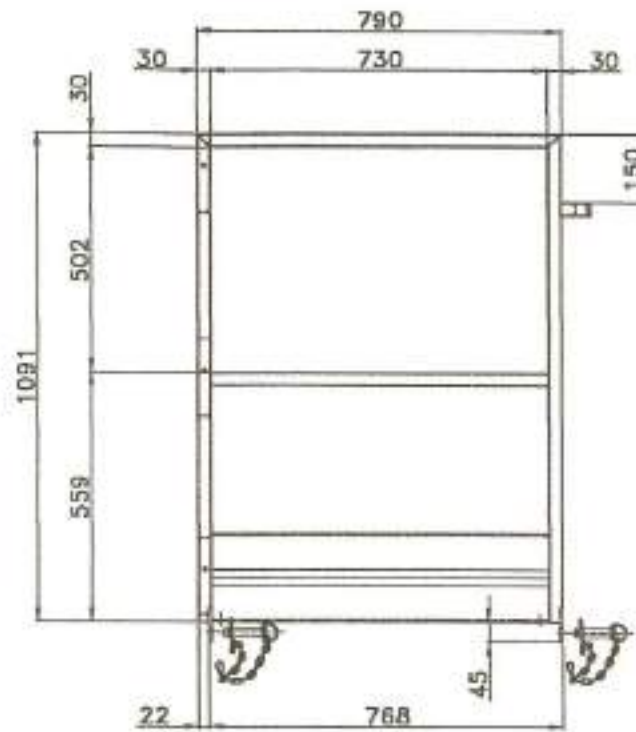

FIG. 4.4.4 Right end guard-rail

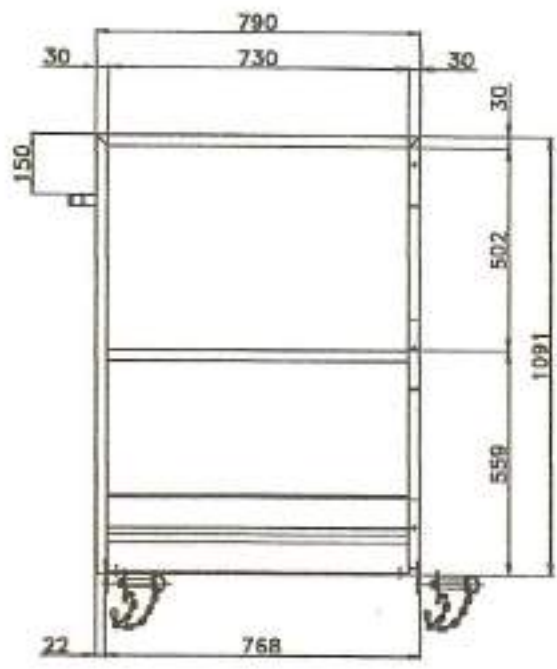

FIG. 4.4.5 Left end guard-rail

4.5) Deck and access stairway

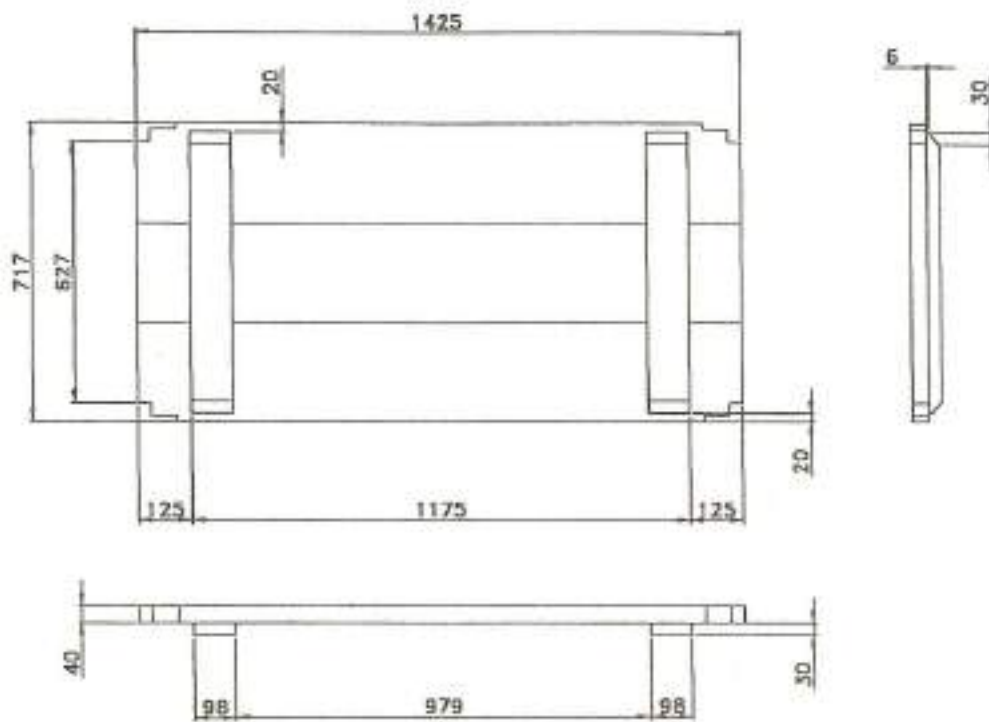

FIG. 4.5.1 Wooden decks